

Misalignment Switch Type MAS 001



OPERATING INSTRUCTIONS

Imprint

Operating Instructions (Original)
(Translation of the German version dated 01.10.2010,
Index G)
Document No.: 94.054899.191

Misalignment Switch, Type MAS 001
Device part no.: 91.050688.001

Release date: 04.10.2010
Change status: Index G

CE mark and conformity

The device meets the requirements of applicable European and national regulations. Conformity has been demonstrated. The manufacturer keeps the applicable declarations and materials on file.

Protective note (as per DIN ISO 16016:2002-5)

The reproduction, distribution and utilization of this document as well as the communication of its contents to others without explicit authorization is prohibited. Offenders will be held liable for the payment of damages. All rights reserved in the event of the grant of a patent, utility model or design.

www.kiepe-elektrik.com

Vossloh Kiepe GmbH
Kiepe-Platz 1
40599 Düsseldorf
Germany

Tel.: +49 (0) 211 / 74 97 – 0
Fax: +49 (0) 211 / 74 97 – 420

Table of contents

1	For your own safety	5
1.1	Intended use	5
1.2	Layout of warning messages	5
2	Transport, storage, and disposal	7
2.1	Transport and packaging	7
2.2	Storage	7
2.3	Disposal	8
3	Description	9
4	Technical data	10
4.1	General technical data	10
4.2	Dimensions	12
5	Mounting and dismounting	13
5.1	Scope of delivery	13
5.2	Mounting	14
5.2.1	Mechanical mounting	14
5.2.2	Electrical connection	16
5.2.3	Commissioning	18
5.3	Dismounting	19



6	Maintenance.....	20
7	Repairs.....	21
7.1	Replacing roller levers.....	21
7.2	Replacing a seal.....	22
8	Ordering devices, replacement parts, and accessories	23
8.1	Ordering devices.....	23
8.2	Ordering replacement parts and accessories	24

1 For your own safety

1.1 Intended use

The MAS 001 misalignment switch is used to monitor conveyor belts for misalignment with continuous conveyors. The misalignment switch MAS 001 is used to protect belts from damage or destruction if the belt is misaligned. The device is designed for use in stationary systems and vehicles.

The documentation at hand is to be considered part of the product and must be retained and be available to the respective owner/user for the entire service life of the product. The documentation must be passed on to each subsequent owner of the product.

The manufacturer is **not liable** for personal injury and property damage arising from non-intended use of the device or unauthorized modifications to the device and its components. Make sure that the intended use is not impaired in any way even after unexpected outside influence on the device.

Intended use refers specifically to the operation of the device in accordance with these **operating instructions**. Work on this device may only be carried out by **qualified personnel** who are familiar with **accident prevention regulations** as well as other generally recognized safety regulations.

By using the equipment as intended, you protect yourself and prevent damage to the equipment and its components.

1.2 Layout of warning messages

Risks are classified in accordance with ISO 3864-2 and ANSI Z535.6 using the keywords

- “Danger,” “Warning,” and “Caution” in the case of bodily injury,
- “Beware” in the case of property damage, and
- “Note” to convey general information.

In this documentation, the Risks and Notes are classified and presented as follows:

Danger!

indicates the immediate threat of danger. Not avoiding this danger will result in death or extremely serious injury (crippling).

Warning!

indicates a possibly dangerous situation. Not avoiding this dangerous situation could result in death or extremely serious injury (crippling).

Caution!

indicates a possibly dangerous situation. Failure to avoid this dangerous situation can result in light or minor injuries.

Beware!

indicates a possibly harmful situation. If this harmful situation is not avoided, the product or something in its vicinity could be damaged.





Note!

“Note” indicates advice on use and other especially helpful information.

Icons

The following icons are used to more clearly define the sources of danger. The icons can appear in reference to any level of danger.

Icon	Type of danger
	Dangers of all types, except those that are labeled with the following icon
	Injuries caused by dangerous voltages and currents.
	Damage caused by electrostatic discharges (ESD protection)

Tab. 1-1: Icons for general sources of danger

2 Transport, storage, and disposal

2.1 Transport and packaging

Select suitable packaging when sending the device or components of the device to Vossloh Kiepe GmbH, e.g. for repairs. In particular, ensure that the components are kept clean and protected from shock and moisture. This prevents damage to the components that may occur during transport, for which the manufacturer accepts no liability.

2.2 Storage

Avoid major temperature fluctuations, as these can lead to condensation that can cause damage to the device and its components.

The permissible storage temperature is from -25 °C to $+70\text{ °C}$.



Damage caused by storage

Dirt or water getting into the device and exposure to weather (e.g. buildup of condensation in the device, sunlight) damage the device and lead to faster deterioration.

Protect the device by storing it in a clean, dry place under stable ambient conditions. If possible, store the device in its original packaging.



Aging of materials!

Materials may age during extended storage, which can have detrimental effects on material properties (for example seals and plastic may become brittle). Properties of lubricants may change due to long storage.

Check devices for damage before using or installing. Do not install any devices that show signs of damage.

2.3 Disposal

Disposal of our products must be performed in accordance with the relevant applicable local, national, and international requirements.

If the product contains consumable operating materials such as oils, greases, and coolants in the form of liquids, pastes, and gas, etc., suitable measures must be taken to collect and dispose of these materials according to applicable local, national, and international requirements. Penetration of these consumable operating materials into the ground, sewer system, and water sources as well as liberation into the atmosphere must always be prevented.

3 Description

The MAS 001 misalignment switch is used to monitor conveyor belts for misalignment with continuous conveyors. The misalignment switch MAS 001 is used to protect belts from damage or destruction if the belt is misaligned. Conveying systems can be turned off in time to prevent overflowing material or malfunctions.

Misalignment switches of type MAS 001 are mounted in pairs on the upper belt before the drive drum, on the lower belt before the deflection drum, and also at critical points at greater axial distances or at material transfer points.

The use of glass-fiber-reinforced polyamide for the housing (1) and the use of stainless steel is aimed especially at the use of the misalignment switches in aggressive environments, e. g. in potash and salt companies, seaports as well as in urea, recycling and composting plants.

Misalignment switches of type MAS 001 each have two switching points in both directions in which the roller lever (3) can be deflected (see Fig. 3-1). When a roller lever (3) is deflected by 10° , an advance warning is given. If the roller lever (3) is deflected by 25° , the misalignment switch actuates the limit switch of the conveyor.

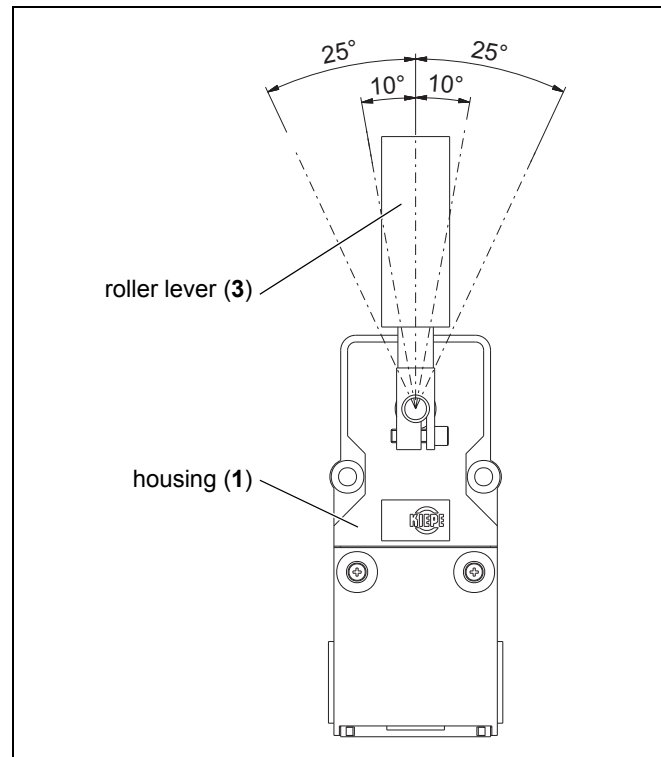

Fig. 3-1: Misalignment switch MAS 001

4 Technical data

4.1 General technical data

EN 60947-5-1 EN 0418 VDE 0110 – Degree of Pollution 4	Low-voltage switchgear, control units and switching elements Safety of machines Insulation coordinates for electrical equipment in low-voltage installations
Suitable for	Control units and systems in accordance with EN 60204: Safety of machines, electrical equipment of machines
Housing	Plastic PA, glass-fiber-reinforced
Fastening	2 screws M 6
Permissible ambient temperature	– 25 °C - + 70 °C
Switching system	2 changers, self-cleaning
Switching points	10° and 25°
Rated insulation voltage U_i	230 V
Rated operating voltage U_e	230 V
Conventional thermal current I_{th}	6 A
Switching capacity (1 switching element) AC-15 DC-13	AC 230 V / 1.5 A DC 60 V / 0.5 A
Protection type	IP 65 in accordance with DIN VDE 470, Part 1 (EN 60529)

Line infeed	Threaded hole for 3 x M 25 x 1.5 1x cable screw joint M 25 x 1.5; sealing area \varnothing 9 mm up to \varnothing 17 mm 2 x dummy plug (11) M 25 x 1.5
Connection conductor cross-section	Max. 2.5 mm ²

5 Mounting and dismounting

5.1 Scope of delivery

The misalignment switch of type MAS 001 is delivered ready for use. The screws M 6 (4) for mechanical fastening are not included with delivery.



Beware!

The device must not be operated unless all openings are sealed with the enclosed screw joint (6) and the dummy plug (11)! Use only the supplied screw joint (6) and dummy plug (11), otherwise the tightness of the device cannot be ensured!

One screw joint (6) and three dummy plug (11) are included in the delivery.

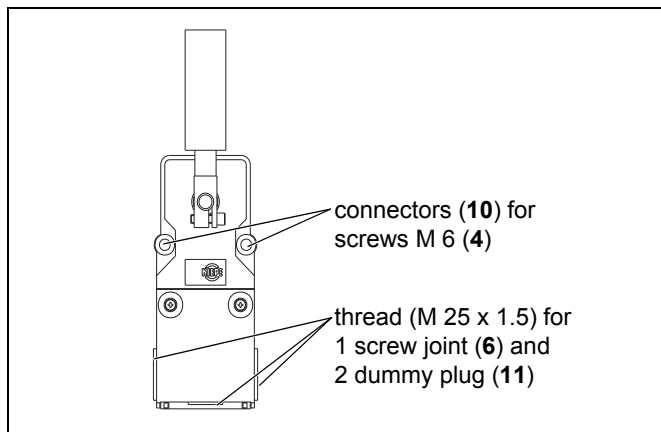

Fig. 5-1: Scope of delivery

5.2 Mounting



Danger of fatal electric shock

Work on the device may be performed only by a qualified electrical technician.

Prior to working, switch off the power supply to the system. Ensure that the system cannot be accidentally switched on. Mask any neighboring components that may be live to prevent contact.



Beware!

The belt misalignment switches are to be used in control circuits only.



Beware!

The device must not be operated unless all openings are sealed with the enclosed screw joint (6) and the dummy plug (11)! Use only the supplied screw joint (6) and dummy plug (11), otherwise the tightness of the device cannot be ensured!

5.2.1 Mechanical mounting



Beware!

Install the misalignment switch so that when the belt is misaligned the edge of the belt activates the roller lever (3) in the lower half of the roller. This will prevent the belt from slipping over the roller lever (3) (see Fig. 5-2)

Misalignment switches of type MAS 001 are mounted in pairs on the upper belt before the drive drum, on the lower belt before the deflection drum, and also at critical

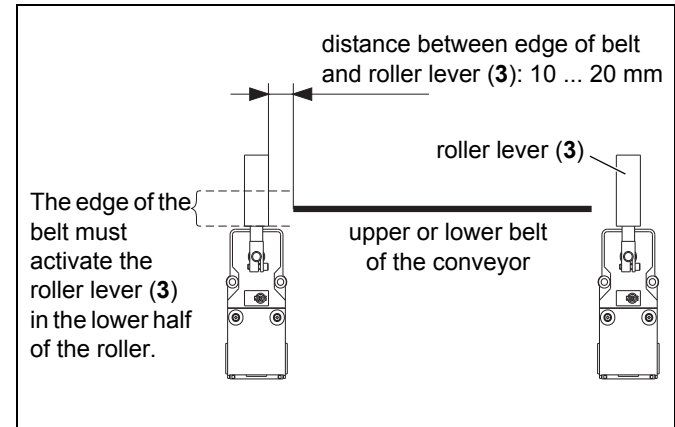

Fig. 5-2: Installing the misalignment switches in pairs on the conveyor belt

points at greater axial distances or at material transfer points (see Fig. 5-2).

1. Prior to working, switch off the power supply to the system. Ensure that the conveyor system cannot be accidentally switched on. Mask any neighboring components that may be live to prevent contact.
2. Attach the misalignment switch with two screws M 6 (4) through the connectors (10) on the conveyor belt structure (see Fig. 5-3).
3. Loosen the socket head screw (9) using a hexagon socket wrench, size 4 (see Fig. 5-3).

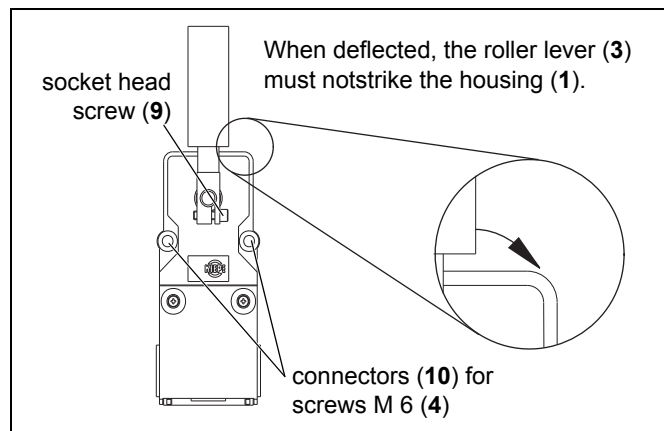

Fig. 5-3: Installing the misalignment switch on the conveyor belt

To prevent rapid wearing of the roller lever (3), you should install the roller lever (3) so that it is positioned about 10 to 20 mm before the belt edge (see Figure 5-2 and 5-3).



Beware!

When tightening the socket head screw (9), ensure that when the roller lever (3) is deflected, the distance to the housing (1) is large enough to prevent the roller lever (3) from striking the housing (1) (see Fig. 5-3).

4. Rotate the roller lever (3) into the required position and tighten the socket head screw (9) to a **tightening torque of 4 Nm to 4.5 Nm**.

5.2.2 Electrical connection



Danger of fatal electric shock

Work on the device may be performed only by a qualified electrical technician.

Prior to working, switch off the power supply to the system. Ensure that the system cannot be accidentally switched on. Mask any neighboring components that may be live to prevent contact.



Danger!

Use only connection cables with a minimum diameter of 9 mm and a maximum diameter of 17 mm. For the permissible line cross sections, please refer to *Chapter 4: „Technical data“, page 11.*



Penetration of dust and moisture if seals are damaged!

If seals are damaged, dust and moisture can penetrate into the device and the device and its components can be damaged.

Check the seals for damage before assembling.

1. Prior to working, switch off the power supply to the system. Ensure that the conveyor system cannot be accidentally switched on. Mask any neighboring components that may be live to prevent contact.
2. Turn a screw joint (6) into the thread (M 25 x 1.5) of the misalignment switch .
3. Seal the other two openings with the dummy plug (11)
4. Loosen the two screws (5) and open the hinged lid (2) (see Fig. 5-5).

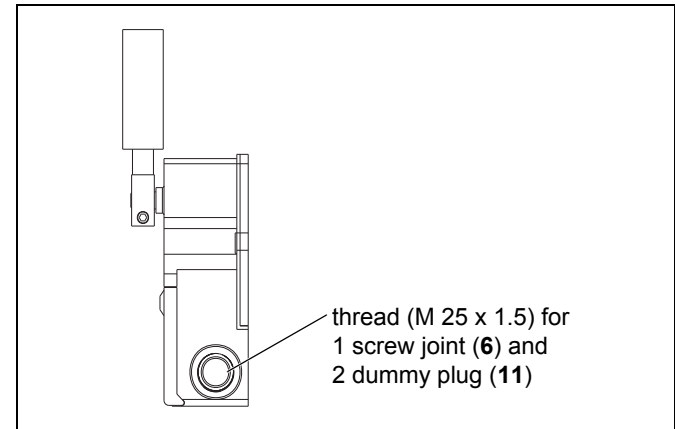

Fig. 5-4: Breaking out lock in the thread

5. Pull the connection cable through the screw joint (6) (see Fig. 5-5).
6. Connect the connection cable to the terminals (7) according to the connection diagram (see Fig. 5-6).

**Beware!**

A device with a damaged seal (13) must not be used! Remove any moisture and dust which has penetrated the device.

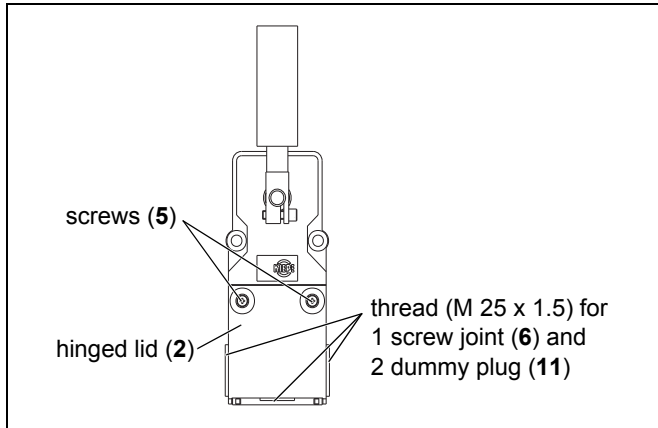

Fig. 5-5: Connection of the misalignment switch

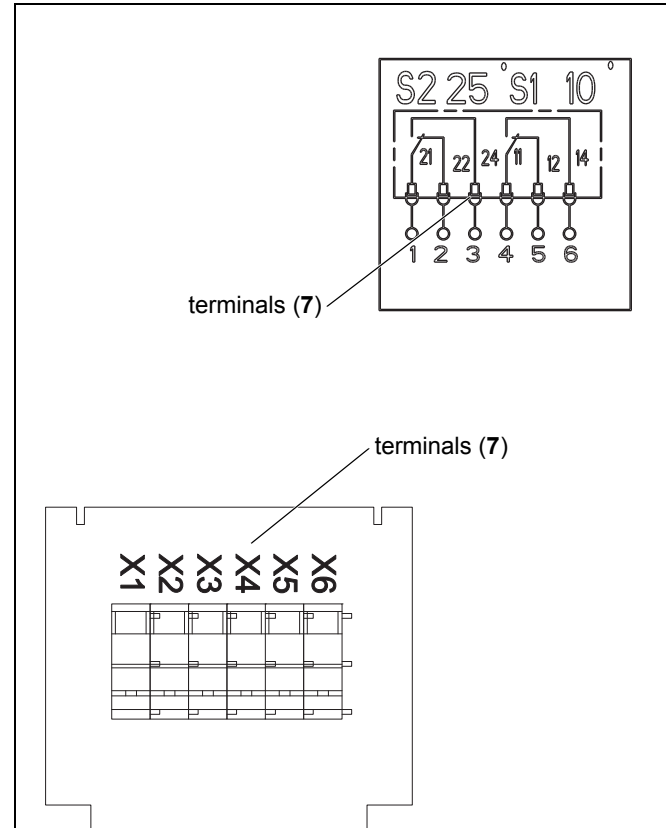

Fig. 5-6: Configuration of the terminals

7. Check the seal (13) in the hinged lid (2) for damage. Replace a damaged seal (13) (see Section 7.2, page 23).
8. Tighten the screw joint (6) to a **tightening torque of XX Nm**.
9. Close the hinged lid (2) and tighten both screws (5) to a **tightening torque of 0.4 Nm** (see Fig. 5-5).
10. Place the misalignment switch in operation (see Section 5.2.3: „Commissioning“, page 19).

5.2.3 Commissioning

1. Before commissioning of the misalignment switch, make certain the seal is secure (see Fig. 5-7):
 - Check to ensure that the screws (5) of the hinged lid (2) are tightened to a **tightening torque of 0.4 Nm**.
 - Check to ensure that the screw joint (6) of the are tightened to a **tightening torque of XX Nm**.
 - Check that the dummy plug (11) are firmly tightened.

2. Check the entire misalignment switch and its components for damage.

Danger!

Do not use damaged misalignment switches or damaged components (e. g. screw joints and seals)! Always replace damaged misalignment switches.

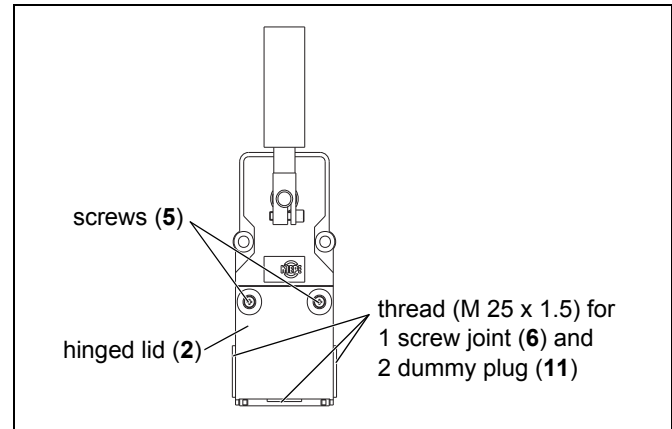

Fig. 5-7: Placing misalignment switch in operation

5.3 Dismounting



Danger of fatal electric shock

Work on the device may be performed only by a qualified electrical technician.

Prior to working, switch off the power supply to the system. Ensure that the system cannot be accidentally switched on. Mask any neighboring components that may be live to prevent contact.

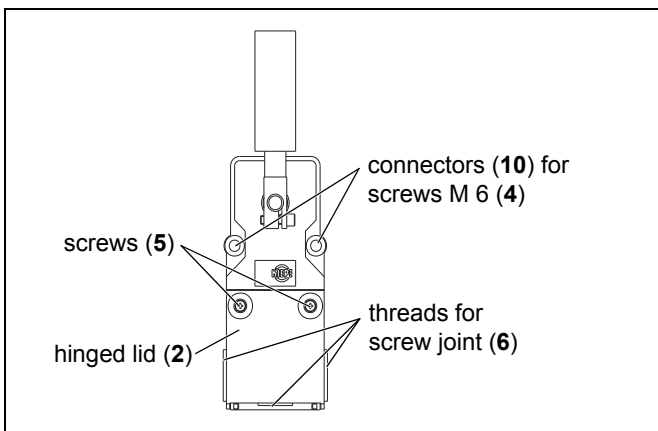

Fig. 5-8: Removing misalignment switch



Danger!

Open the misalignment switch only if the misalignment switch is de-energized!

1. Prior to working, switch off the power supply to the system. Ensure that the conveyor system cannot be accidentally switched on. Mask any neighboring components that may be live to prevent contact.
2. Open the hinged lid (2) by loosening both screws (5) (see Fig. 5-8).
3. Loosen the screw joint (6).
4. Loosen all electrical connections (see Fig. 5-6) and pull the connection cable out of the misalignment switch (see Fig. 5-8).
5. Loosen both screws M 6 (4) and remove the misalignment switch (see Fig. 5-8).

6 Maintenance

Check the misalignment switch at regular intervals (about every three months) to ensure that they are in good condition and in perfect working order.



Danger!

Do not use damaged misalignment switches or damaged components (e. g. screw joints and seals)!
Always replace damaged misalignment switches.

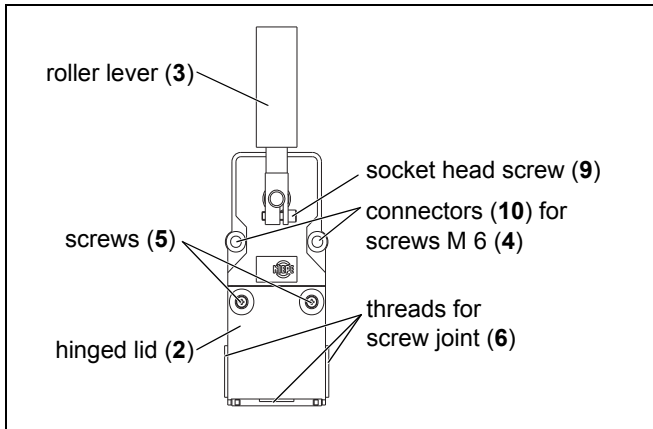

Fig. 6-1: Removing misalignment switch

7 Repairs

7.1 Replacing roller levers



Danger of fatal electric shock

Work on the device may be performed only by a qualified electrical technician.

Prior to working, switch off the power supply to the system. Ensure that the system cannot be accidentally switched on. Mask any neighboring components that may be live to prevent contact.

1. Prior to working, switch off the power supply to the system. Ensure that the conveyor system cannot be accidentally switched on. Mask any neighboring components that may be live to prevent contact.
2. Loosen the socket head screw (9) using a hexagon socket wrench, size 4 (see Fig. 5-3) and pull the roller lever (3) off the shaft (12).
3. Place the new roller lever (3) on the shaft (12).

To prevent rapid wearing of the roller lever (3), you should install the roller lever (3) so that it is positioned about 10 to 20 mm before the belt edge (see Figure 5-2 and 5-3).



Beware!

When tightening the socket head screw (9), ensure that when the roller lever (3) is deflected, the distance to the housing (1) is large enough to prevent the roller lever (3) from striking the housing (1) (see Fig. 5-3).

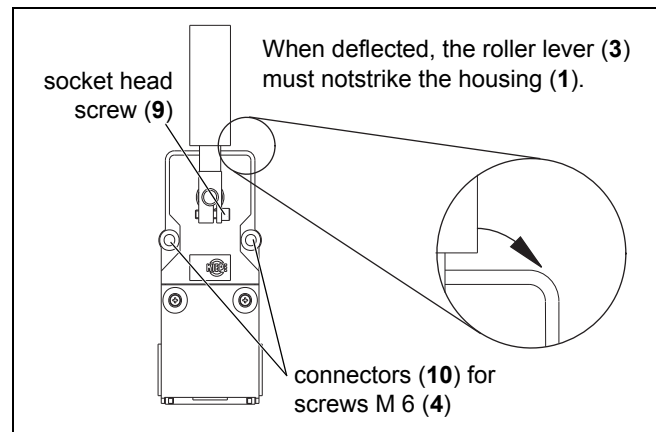

Fig. 7-1: Misalignment switch: Replace roller levers

4. Rotate the roller lever (3) into the required position and tighten the socket head screw (9) to a **tightening torque of 4 Nm to 4.5 Nm**.
5. Close the hinged lid (2) of the misalignment switch MAS 001 and tighten both screws (5) to a **tightening torque of 0.4 Nm** (see Fig. 5-5).

7.2 Replacing a seal



Danger of fatal electric shock

Work on the device may be performed only by a qualified electrical technician.

Prior to working, switch off the power supply to the system. Ensure that the system cannot be accidentally switched on. Mask any neighboring components that may be live to prevent contact.

1. Prior to working, switch off the power supply to the system. Ensure that the conveyor system cannot be accidentally switched on. Mask any neighboring components that may be live to prevent contact.
2. Open the hinged lid (2) by loosening both screws (5) (see Fig. 5-8).
3. Remove seal (13) from the hinged lid (2). When removing the seal remnant, ensure that the housing (1) is not damaged.
4. Stick the new seal (13) into the hinged lid (2).

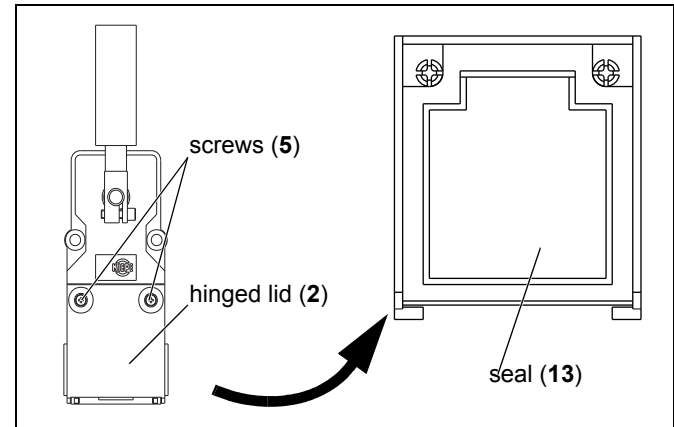

Fig. 7-2: Misalignment switch: Replacing seal in the hinged cover

8 Ordering devices, replacement parts, and accessories

8.1 Ordering devices

Please specify the following information for each order
(for the company's address, see the Imprint):

1. **Type designation of the misalignment switch**
(see the rating plate on the housing): MAS 001
2. **Device part no.** (see rating plate on the housing):
e. g. 91.050688.001

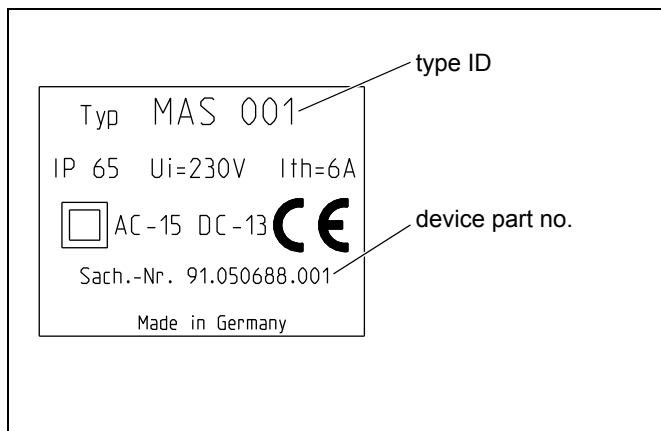

Fig. 8-1: Printed image

8.2 Ordering replacement parts and accessories

Please specify the following information for each order
(for the company's address, see the Imprint):

1. **Type designation of the misalignment switch**
(see the rating plate on the housing): MAS 001
2. **Device part no.** (see rating plate on the housing):
e. g. 91.050688.001
3. **Order text and order number** (see table):

Item	Order text	Order number
3	Switch lever with roller (roller lever)	94.037860.001
6	Cable screw joint	113.51.00.20.10
11	Screw plug (dummy plug)	710.21.02.04.02
13	Seal	94.050680.005

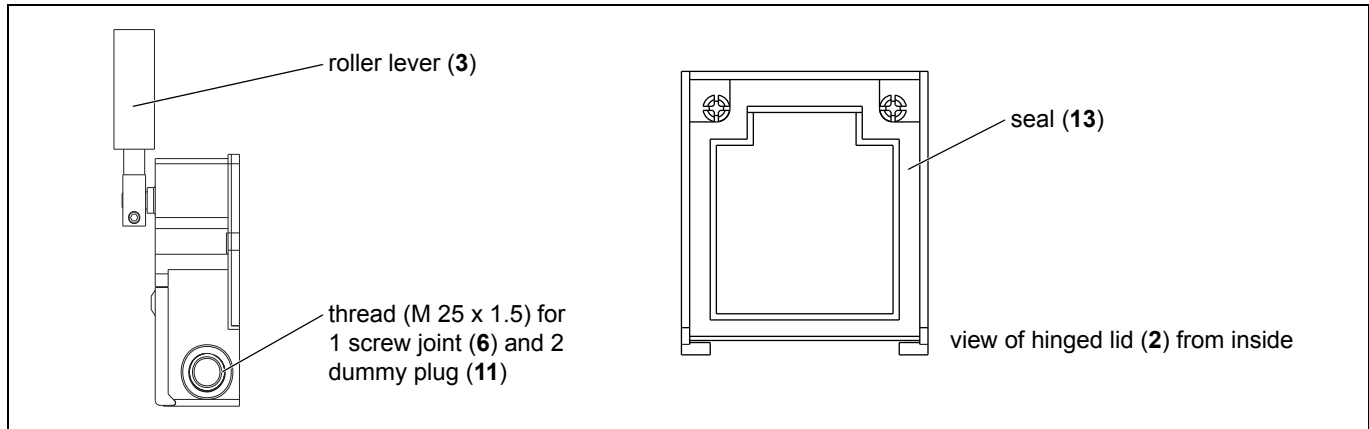

Fig. 8-2: Replacement parts

www.kiepe-elektrik.com

Vossloh Kiepe GmbH
Kiepe-Platz 1
40599 Düsseldorf
Germany

Tel.: +49 (0) 211 / 74 97 – 0
Fax: +49 (0) 211 / 74 97 – 420