

Pull-rope emergency stop switch Type HENEX and SEGEX



OPERATING INSTRUCTIONS

Legal notice

Operating instructions (Translation of original)
Document no.: 94.058 816.191

Pull-rope emergency stop switch, Type HENEX and
SEGEX

Product number: various

Date of issue: 16.08.2010

Update status: Index F

CE conformity certificate

The device complies with the relevant European and
national regulations.

CE conformity has been certified; the relevant records
and documents are in the hands of the manufacturer.

Protective note (as per DIN ISO 16016:2002-5)

Forwarding and duplicating this document, as well as
using or revealing its contents are prohibited without
written approval. Noncompliance is subject to
compensatory damages. All rights reserved with regard
to patent claims or submission of design or utility patent.

www.kiepe-elektrik.com

Vossloh Kiepe GmbH
Kiepe-Platz 1
40599 Düsseldorf
Germany

Tel.: +49 (0) 211 / 74 97 – 0
Fax: +49 (0) 211 / 74 97 – 420
E-mail: info@vkd.kiepe-elektrik.com

Table of contents

- 1 For your safety7
 - 1.1 Intended use7
 - 1.2 Design of warnings8

- 2 Transport, storage and disposal10
 - 2.1 Transport and packaging10
 - 2.2 Storage10
 - 2.3 Disposal10

- 3 Description11

- 4 Technical data13
 - 4.1 General technical data13
 - 4.2 Device identification15
 - 4.3 Device variants16
 - 4.4 Dimensions17

- 5 Mounting and dismounting19
 - 5.1 Scope of delivery19
 - 5.2 Mounting20
 - 5.2.1 Important mounting instructions20
 - 5.2.2 Accessories for mounting21

CONFIDENTIAL

5.2.3	Mechanical mounting	22
5.2.4	Electrical connection	27
5.3	Dismounting	31
6	Maintenance and repair.....	32
7	Ordering devices, replacement parts and accessories	34
7.1	Ordering devices.....	34
7.2	Ordering replacement parts and accessories	35

1 For your safety

1.1 Intended use

The HENEX and SEGEX pull-rope emergency stop switches have been designed for use in conveyor belt systems. The device is intended for use in stationary installations and vehicles.

Pull-rope emergency stop switches are approved for use in the presence of combustible dust in accordance with EN 61241-0: 2006 "Electrical apparatus for use in the presence of combustible dust" and EN 61241-1: 2004 "Protection by enclosures". Pull-rope emergency stop switches are marked with Ex II 2D Ex tD A21 IP 65 T 85 °C and can be used in Zones 21 and 22, Equipment Group II, Categories 2 and 3.

Pull-rope emergency stop switches may not be used underground nor in Zones 0, 1, 2, and 20!

The documentation at hand is to be considered part of the product and must be retained and be available to the respective owner/user for the entire service life of the product. The documentation must be passed on to each subsequent owner of the product.

The manufacturer is **not liable** for personal injury and property damage arising from non-intended use of the device or unauthorized modifications to the device and

its components. Make sure that the intended use is not impaired in any way even after unexpected outside influence on the device.

Intended use refers specifically to the operation of the device in accordance with these **operating instructions**. Work on this device may only be carried out by **qualified personnel** who are familiar with **accident prevention regulations** as well as other generally recognized safety regulations.

By using the equipment as intended, you protect yourself and prevent damage to the equipment and its components.

Design of warnings

Risks are classified in accordance with ISO 3864-2 and ANSI Z535.6 using the keywords

- "Danger," "Warning," and "Caution" in the case of bodily injury,
- "Beware" in the case of property damage, and
- "Note" to convey general information.

In this documentation, the Risks and Notes are classified and presented as follows:

**Danger!**

indicates the immediate threat of danger. Not avoiding this danger will result in death or extremely serious injury (crippling).

**Warning!**

indicates a possibly dangerous situation. Not avoiding this dangerous situation could result in death or extremely serious injury (crippling).

**Caution!**

indicates a possibly dangerous situation. Failure to avoid this dangerous situation can result in light or minor injuries.

**Beware!**

indicates a possibly harmful situation. If this harmful situation is not avoided, the product or something in its vicinity could be damaged.

**Note!**

“Note” indicates advice on use and other especially helpful information.

Icons

The following icons are used to more clearly define the sources of danger. The icons can appear in reference to any level of danger.



Icon	Type of danger
	Dangers of all types, except those that are labeled with the following icon
	Injuries caused by dangerous voltages and currents.
	Damage caused by electrostatic discharges (ESD protection)

Table 1-1: Icons for general sources of danger

2 Transport, storage and disposal

2.1 Transport and packaging

Select suitable packaging when sending the device or components of the device to Vossloh Kiepe GmbH, e.g. for repairs. In particular, ensure that the components are kept clean and protected from shock and moisture. This prevents damage to the components that may occur during transport, for which the manufacturer accepts no liability.

2.2 Storage

Avoid major temperature fluctuations, as these can lead to condensation that can cause damage to the device and its components.

Permissible storage temperature: See *chapter 4: "Technical data", page 12*



Damage caused by storage

Dirt or water getting into the device and exposure to weather (e.g. buildup of condensation in the device, sunlight) damage the device and lead to faster deterioration.

Protect the device by storing it in a clean, dry place under stable ambient conditions. If possible, store the device in its original packaging.

2.3 Disposal

Only materials that are not considered hazardous according to current engineering practice are used for Vossloh Kiepe GmbH products. Furthermore, we develop products that can be recycled after intended use. In our selection of raw materials and components, we favor reusable materials. This choice of materials used does not compromise product safety in any way.

3 Description

Pull-rope emergency stop switches are used in conveyor systems for emergency shutdown. The devices are designed for long service lives under severe ambient conditions.

How the emergency stop function works

The trigger lever (1) for the pull-rope emergency stop switch is actuated via a pull wire (3) which is stretched along the conveyor system (see fig. 3-1).



Warning!

The tear rope (3) should be stretched along the conveyor system so that it is visible along its entire length.

Actuating the trigger lever (1) by using the pull wire (3) causes the switch cylinder (20) to move to the "Off" position, and the trigger lever (1) is decoupled (see fig. 3-2). No further switching operation is then possible.

The pull-rope emergency stop switch is tripped by the pull wire (3) and is bi-directional in operation.

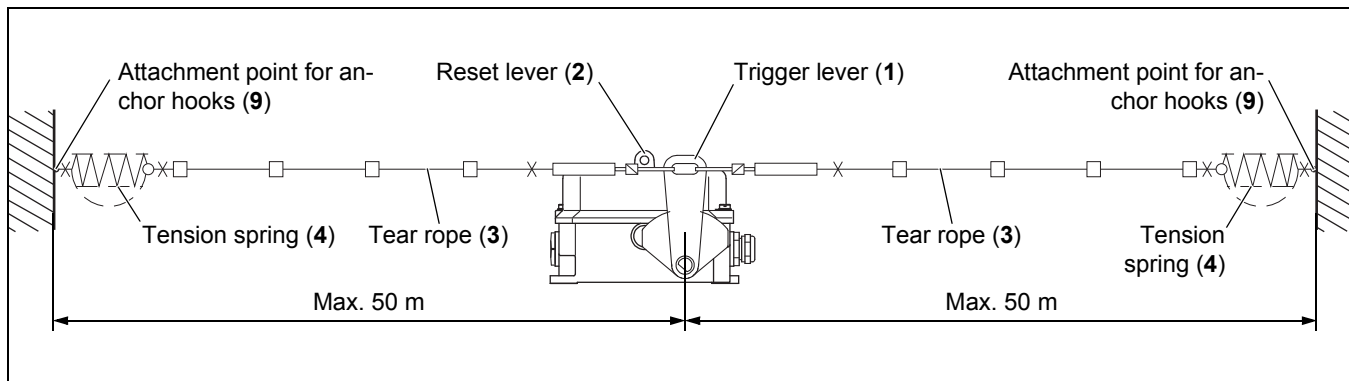

Fig. 3-1: Function

The pull wire length (3) may vary according to local condition, but it must not exceed 50 m on either side. The tension springs (4) at both ends of the pull wire (3) ensure that the pull wire is foolproof. If the pull wire (3) breaks, the pull-rope emergency stop switch is actuated by the opposite tension spring (4)..

Warning!

After actuating and before resetting the pull-rope emergency stop switch, the installation must be checked along the entire length of the tear rope (3) in order to establish why the pull-rope emergency stop switch was actuated.

The conveyor system can only be restarted if the reset lever (2) has been used to unlock the pull-rope emergency stop switch at the installation site.

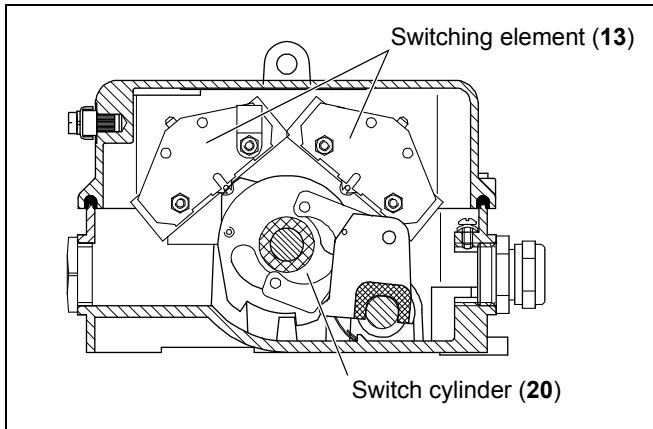

Fig. 3-2: Switch cylinder and switching elements

4 Technical data

4.1 General technical data

In compliance with the following standards and regulations	EN 61241-0: 2006 EN 61241-1: 2004 EN 60947-5-1, EN 60947-5-5, EN 13850, VDE 0110 – Degree of Pollution 3, UVV – VBG 10
Suitable for	Controls and installations according to EN 60204
Casing	HENEX: Aluminum SEGEX: Gray cast iron
Finish	DD enamel
Mounting	HENEX: 2 slotted holes for M 8 screws SEGEX: 2 slotted holes for M 10 screws
Permissible Ambient Temperature (VDE 0660)	- 25 °C _i + 75 °C, <i>also see section 4.3, page 15</i>
Max. operating temperature of casing	85 °C
Max. altitude above sea level	2,000 m (contact manufacturer for installation at higher altitudes)
Protection standard	IP 65 according to EN 60529
Switching system	Cam switch, max. 6 forced switching devices, <i>also see section 4.3, page 15</i>
Rated insulation voltage U _i	AC 380 V, DC 440 V
Rated operating voltage U _e	AC 240 V, DC 250 V

Conventional thermal current I_{th}	16 A
Breaking capacity AC-13 ($\cos\varphi = 0.65$) DC-13 (L/R = 100 ms)	$U_e = AC\ 240\ V, I_e = 10\ A$ $U_e = DC\ 24\ V, I_e = 2.1\ A$ $U_e = DC\ 60\ V, I_e = 0.9\ A$

**Warning!**

Use only screwed cable glands and dummy plugs recommended by the manufacturer and supplied with the device. These screwed cable glands and dummy plugs are designed in compliance with EU design sample test certification. If other screwed cable glands and dummy plugs are used, the device type approval may be rendered void.

Conductor infeed	Threaded hole for 2 x M 25 x 1.5, <i>also see section 4.3, page 15</i> 1 x Screwed cable gland M25 x 1.5; sealing area \varnothing 11.5 mm to \varnothing 15.5 mm 1 x Dummy plug M 25 x 1.5
Line connection cross-section	Max. 2.5 mm ²
Potential equalization connection	Connectable lines: 4 mm ² fine-strand, 6 mm ² unifilar
Protective conductor connection	In the casing, M 4
Protective conductor cross-section	Max. 2.5 mm ² , but at least the width of the connection lead
Line connection cross-section	Max. 2.5 mm ²
Potential equalization connection	Connectable lines: 4 mm ² fine-strand, 6 mm ² unifilar

4.2 Device identification

The devices are marked with a device identification number consisting of an 8-digit basic number and a 3-digit variant number:

Type	Basic number	Variant number
HENEX	91.058 642.	see section 4.3, page 15
SEGEX	91.058 644.	see section 4.3, page 15

You will find the exact type and variant number on the rating plate on the exterior of the casing.



Abb. 4-1: Printed image

4.3 Device variants¹

Variant number	Type	Technical data (see section 4.1)
0xx, 1xx	Basic device	–
2xx	Basic device with Dupline module	<i>also see the "DUPLINE module for pull-rope emergency stop switches" operating instructions: HENEX 21x: 94.063420.101 HENEX 22x, HENEX 23x: 94.063421.101 SEGEX 21x: 94.063422.101 SEGEX 22x, SEGEX 23x: 94.063423.101</i>
3xx	Basic device	additional screwed cable gland
4xx	Basic device	additional switch configuration
5xx	–	–
6xx	–	–
7xx	Basic device with expanded temperature range	–
8xx	–	–
9xx	Special devices	<i>HENEX 911, also see the "DUPLINE module for pull-rope emergency stop switches" operating instructions: 94.063420.101</i>

CONFIDENTIAL

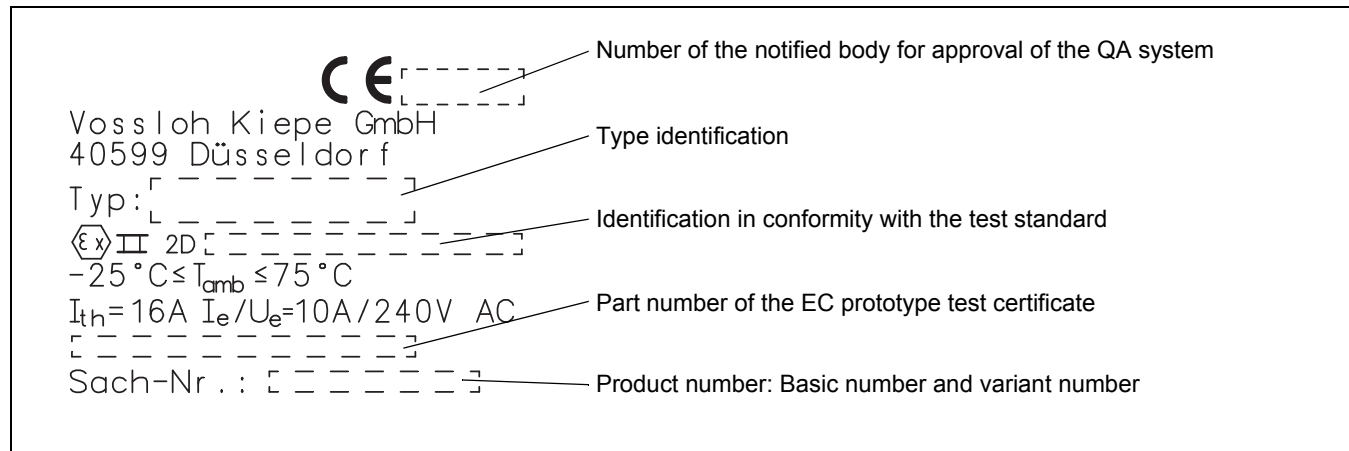
1. Deviations are possible for certain types.

4.4 Dimensions

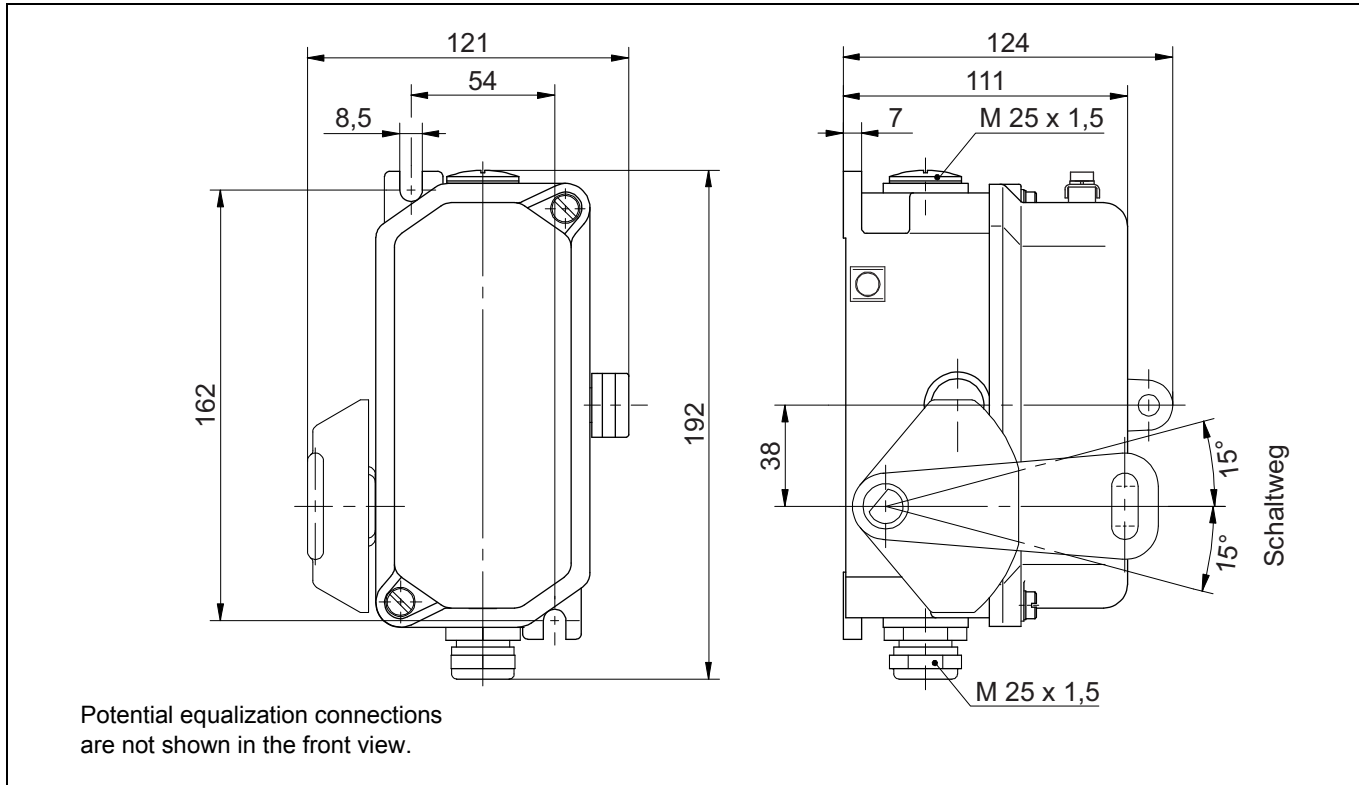

Fig. 4-2: HENEX dimensions

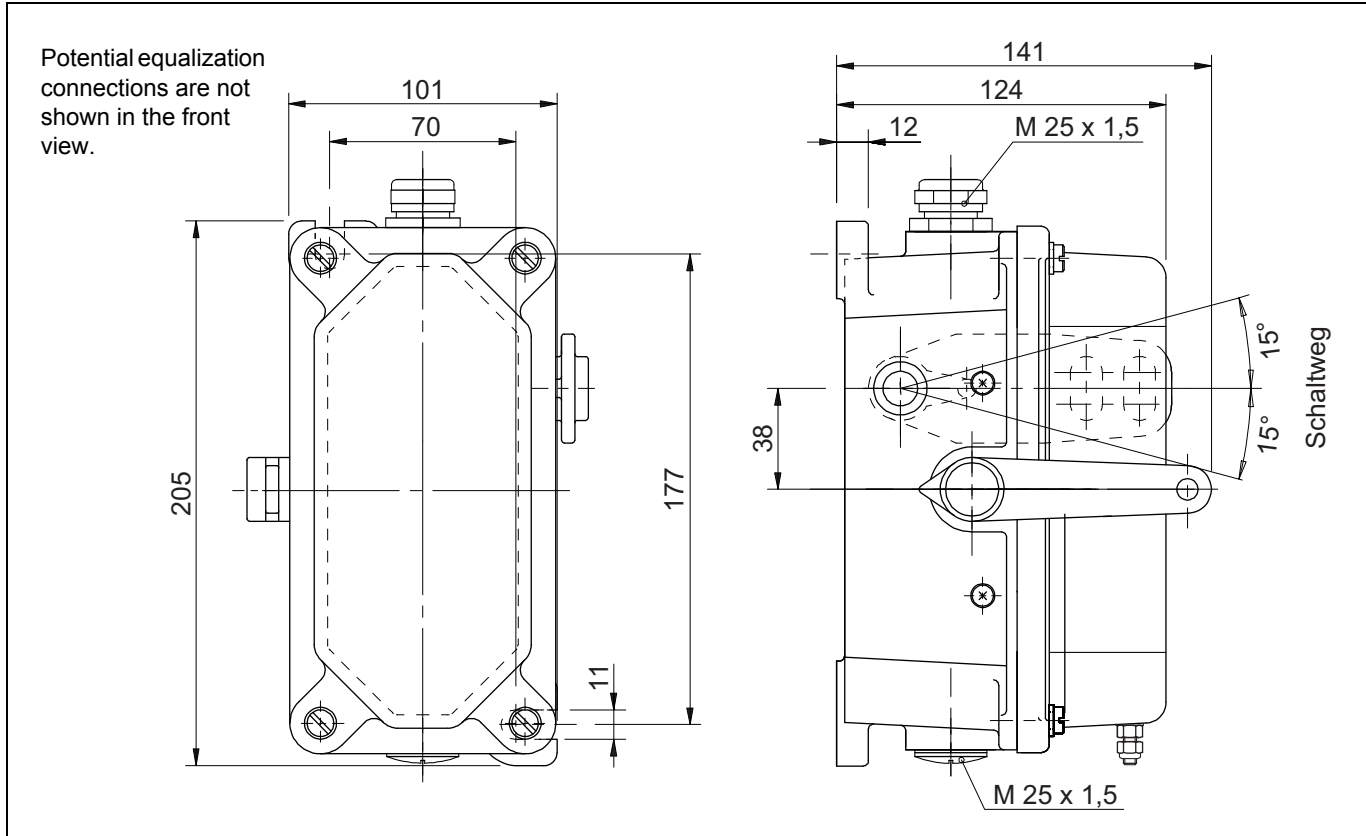

Fig. 4-3: SEGEX dimensions

5 Mounting and dismounting

5.1 Scope of delivery

The pull-rope emergency stop switches are delivered ready to operate. The screws for mechanical fastening are not included in the scope of delivery. One screwed cable gland (17) and one dummy plug (18) are included in the scope of delivery (see fig. 5-1).

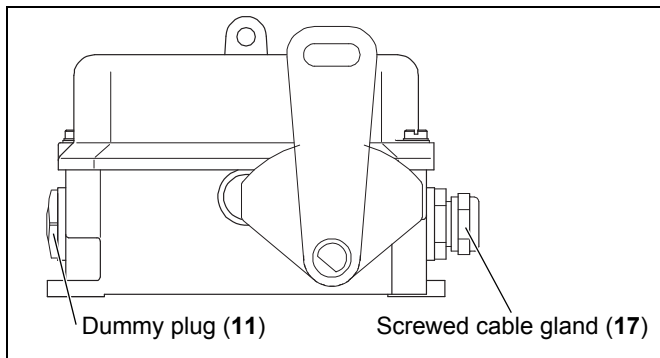

Fig. 5-1: Scope of delivery



Warning!

The device must only be operated when all three holes are closed with the supplied cable gland (17) and the dummy plugs (11).

Use only screwed cable glands (17) and dummy plugs (11) recommended by the manufacturer and supplied with the device. These screwed cable glands (17) and dummy plugs (11) are designed in compliance with EU design sample test certification. If other screwed cable glands (17) and dummy plugs (11) are used, the device type approval may be rendered void.

5.2 Mounting

5.2.1 Important mounting instructions

Observe the following notes while mounting to ensure that the pull-rope emergency stop switches are operated properly. If conditions should deviate from those indicated, consult Vossloh Kiepe GmbH (*see legal notice for company address*).



Achtung!

Die Seilzugnotschalter dürfen nur in Steuerstromkreisen eingesetzt werden.

- When mounting, only use KIEPE accessories (*see section 5.2.2, page 20*). This applies in particular to the screwed cable gland (17) and the dummy plug (18) provided with the pull-rope emergency stop switch.
- Ambient and storage temperature range of the pull-rope emergency stop switches: *see chapter 4, page 12*)
- The following instructions for setting the tear rope system are applicable during assembly at an ambient temperature of about + 15 °C.

If the ambient conditions are strongly deviating, contact Vossloh Kiepe GmbH (*for the company address, see the Legal Notice*).

- The pull-rope emergency stop switch must be mounted at the midway point between the attachment points of the anchor hook (9). Deviation of up to 3 % of the distance between the pull-rope emergency stop switch and the relevant attachment point is permitted.
- The distance between the attachment points of the anchor hooks (9) must not exceed 100 m.
- The attachment points for the anchor hooks (9) must be constructed from sturdy mechanical components.
- The distance between the eyebolts (8) must not exceed 2.5 m (*see fig. 5-2*).

5.2.2 Accessories for mounting

You required two screws **(5)** with the thread diameter M 8 for HENEX or M 10 for SEGEX in order to fasten the pull-rope emergency stop switches.

You will also require the following KIEPE accessories for further mounting of the pull-rope emergency stop switches on the conveyor structure (see *figures 5-2 and Section 7.2: "Ordering replacement parts and accessories", page 34*):

- Tear rope **(3)**, Ø 3 mm
- Egg-shaped clamps **(7)**
- Eyebolts **(8)**, M 12 x 60
- Anchor hooks **(9)**, M 10
- Tension spring **(4)**, 170 x Ø 20 mm
- Turnbuckles **(6)**

5.2.3 Mechanical mounting



Danger of fatal electric shock

Work on the device may be performed only by a qualified electrical technician.

Prior to working, switch off the power supply to the system. Ensure that the system cannot be accidentally switched on. Mask any neighboring components that may be live to prevent contact.



Warning!

The tear rope (3) should be stretched along the conveyer system so that it is visible along its entire length.

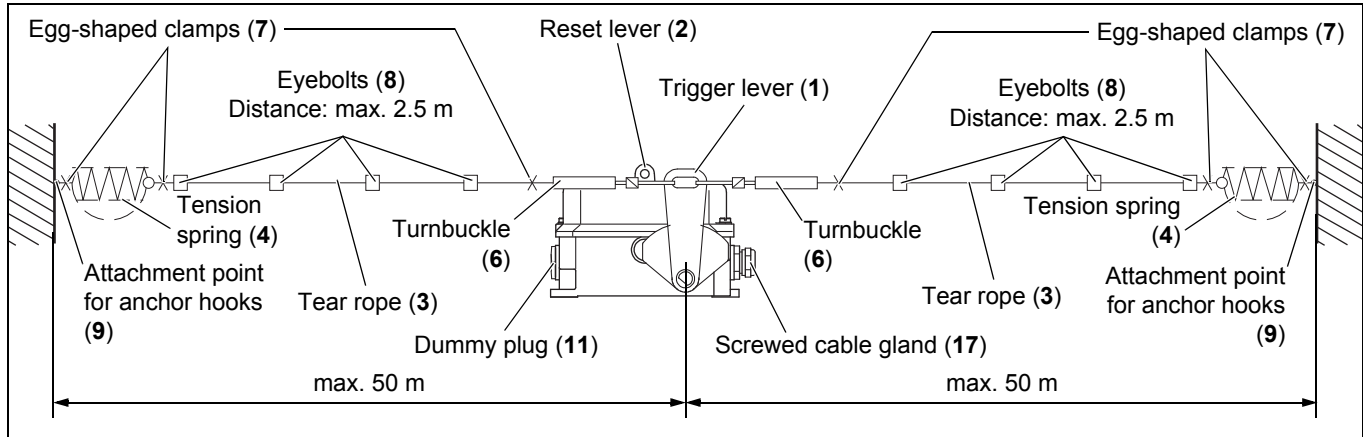

Fig. 5-2: Mounting on the conveyor structure

Mounting on the conveyor structure

1. Prior to working, switch off the power supply to the system. Ensure that the conveyor system cannot be accidentally switched on. Mask any neighboring components that may be live to prevent contact.
2. Secure the pull-rope emergency stop switch *centered* between the attachment points on the conveyor structure (*Mounting dimensions see Section 4.4, page 16*). In doing so, the actuating lever (1) must point towards the belt. Attach the pull-rope emergency stop switch by screwing two screws through the slotted holes (*see fig. 5-3*).

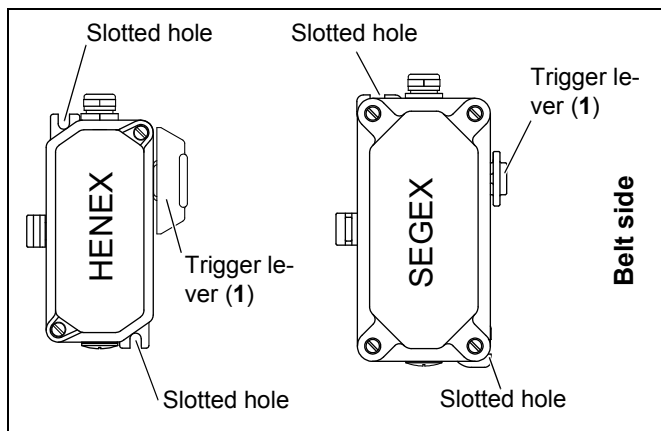

Fig. 5-3: Mounting the pull-rope emergency stop switch



Warning!

The attachment points for the anchor hooks (9) must be constructed from sturdy mechanical components, which the anchor hooks (9) cannot break away from when actuating the pull wire (3).

3. Place the anchor hooks (9) on the attachment points (*see fig. 5-2*).
4. Hook the tensions springs (4) onto the anchor hooks (9) (*see fig. 5-4*).

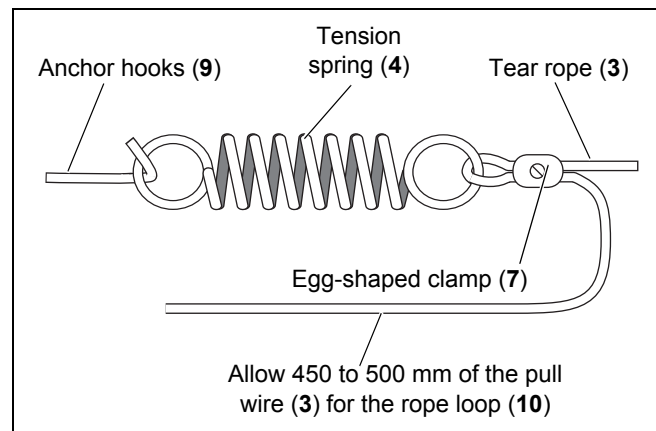

Fig. 5-4: Attaching the tear rope onto the tension spring

- Thread the end of the tear rope (3) through the eye of the tension spring (4). Pull the tear rope (3) about 450 to 500 mm through the eye, so that it can form a rope loop (10) at that end *to complete* the mounting procedure (see fig. 5-4).



Note!

Rope loops (10) are designed to limit the actuating travel of the the tear rope (3) and prevent the tension spring (4) from overextending. The maximum extension of the tension spring (4) is approximately 400 mm.

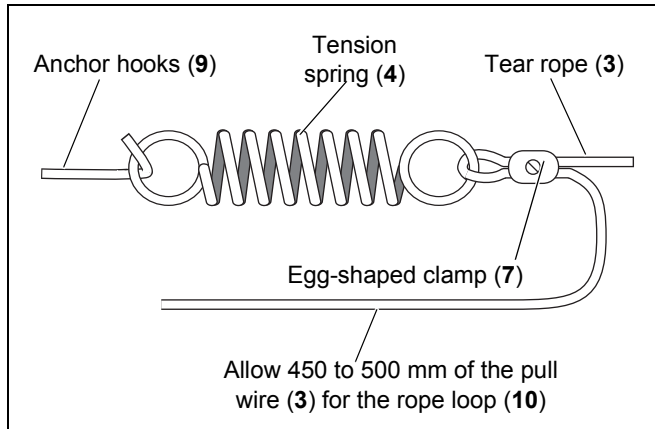

Fig. 5-5: Attaching the tear rope onto the tension spring

- Use an egg-shaped clamp (7) to attach the tear rope (3) to the tension spring (4) (see fig. 5-6).
- Fix the eyebolts (8) to the conveyor structure to guide the pull wire (3).
Distance between eyebolts (8): Max. 2.5 m
- Pull the tear rope (3) through the eyebolts (8).

Setting the spring force

Centring the trigger lever (1) makes it resistant to temperature changes. The tension springs (4) compensate for any extension or contraction of the tear rope (3) caused by temperature changes (see fig. 5-7).

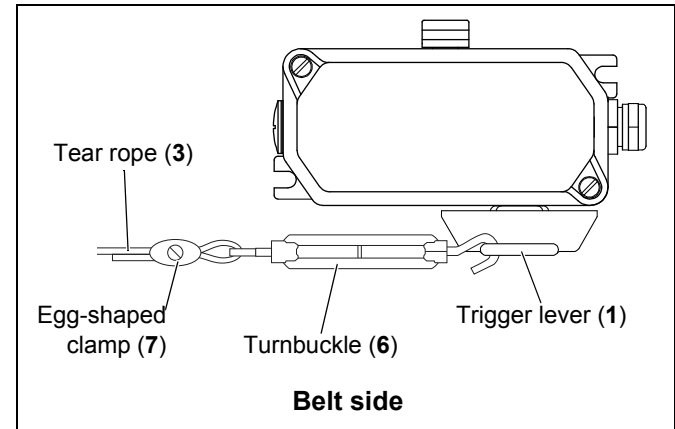

Fig. 5-6: Attaching the turnbuckle

Warning!

If the tear rope (3) tears, the pull-rope emergency stop switch must be actuated by the tension spring (4) on the other side.

9. Release the tension of one turnbuckle (6) completely (see fig. 5-8).
10. Put one end of the tear rope (3) through the eye of the turnbuckle (6) and hook the turnbuckle (6) into the trigger lever (1).

Warning!

The pull wire (3) may be up to 50 meters long in each direction.

11. Tighten the tear rope (3) so that the tension spring (4) is extended by 35 mm (see fig. 5-7).
12. Attach this end of the tear rope (3) using an egg-shaped clamp (7).

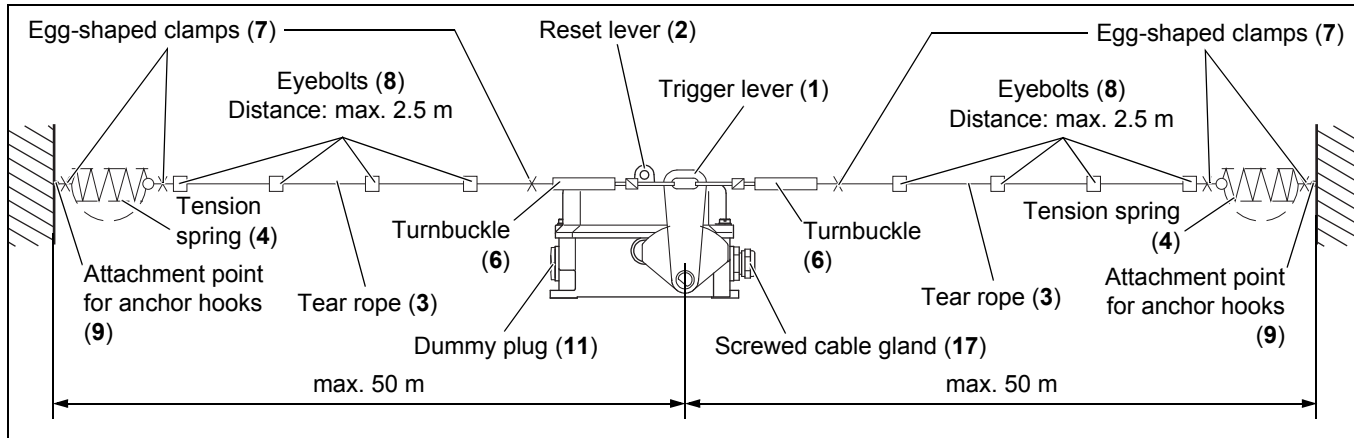

Fig. 5-7: Mounting on the conveyor structure

13. Remove the turnbuckle (6) again. Unlock the pull-rope emergency stop switch by using the reset lever (2) (see fig. 5-7).
14. Repeat steps 5 - 12 for installing the tear rope (3) on the other side of the pull-rope emergency stop switch.
15. Now hook both turnbuckles (6) into place and operate the actuating lever (1) of the pull-rope emergency stop switch.
The trigger lever (1) can now be moved.

16. Place the trigger lever (1) in the middle using the turnbuckles (6) and adjust the length of the tightened tension springs (4) to 210 mm (see fig. 5-7).



Beware!

Ensure that rope loops (10) are formed on both tension springs.

Rope loops (10) are designed to limit the distance the pull wire (3) travels when actuated and prevents the tension spring (4) from overextending (see fig. 5-9). The maximum extension of the tension spring (4) is approximately 400 mm.

17. Form the rope loops (10) on both tension springs (4) as follows:
 - a. Place the section of tear rope (3) provided for the rope loop (10) along the tension spring (4) (see fig. 5-9, above).
 - b. Use the end of the rope loop (10) to make a fastening loop that stops about 50 mm from the end of the tension spring (4) (see fig. 5-9).
 - c. Use an egg-shaped clamp (7) to attach the rope loop (10) to the anchor hook (9) (see fig. 5-9, below).

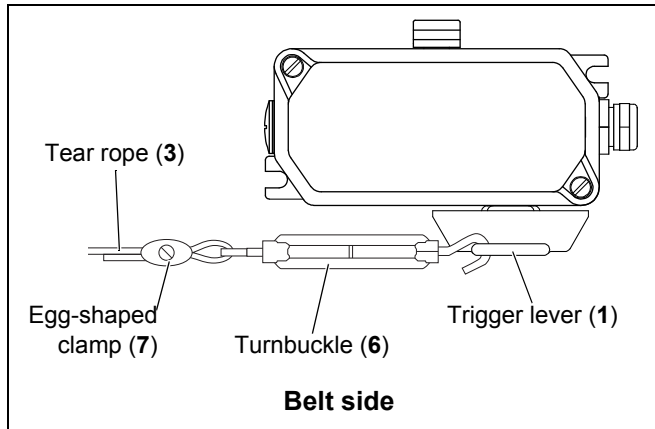

Fig. 5-8: Attaching the turnbuckle

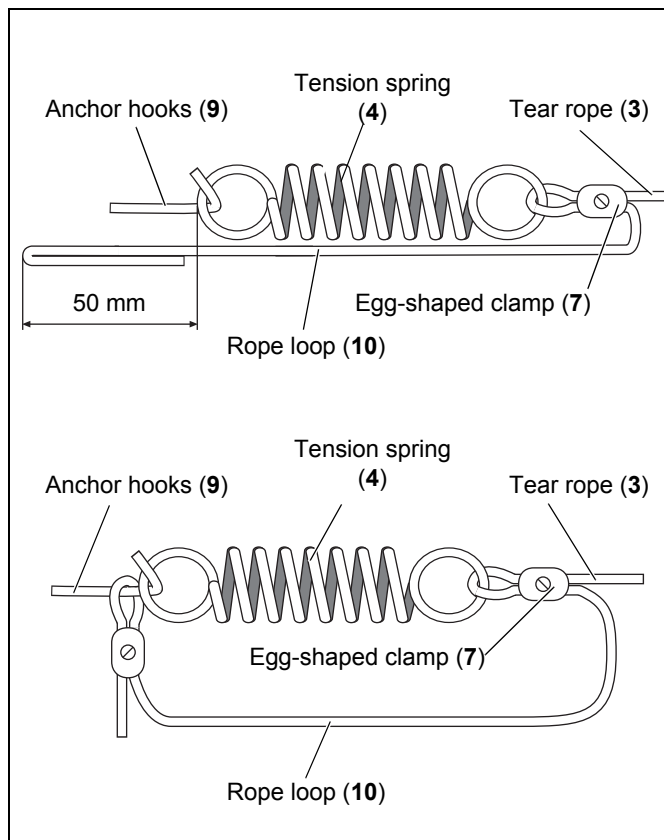

Fig. 5-9: Forming the rope loop

5.2.4 Electrical connection



Risk of explosion!

Never open the rope-pull emergency stop switch in an explosive, dust-polluted area.

Prevent dust and moisture from coming into contact with the rope-pull emergency stop. As required, remove any dust which has entered the unit. Seal the cover immediately after making the electrical connection.



Danger of fatal electric shock

Work on the device may be performed only by a qualified electrical technician.

Prior to working, switch off the power supply to the system. Ensure that the system cannot be accidentally switched on. Mask any neighboring components that may be live to prevent contact.



Danger!

Only use connection cables with a diameter of at least 11 mm up to a maximum of 16 mm. The permissible conductor cross-sections are found in (see chapter 4: "Technical data", page 12).

1. Prior to working, switch off the power supply to the system. Ensure that the conveyor system cannot be accidentally switched on. Mask any neighboring components that may be live to prevent contact.
2. Open the cover (12) of the pull-rope emergency stop switch by releasing the two or four screws (11) (see fig. 5-10).
3. Loosen the nut on the screwed cable gland (17) and thread the connection cable (Ø 11.5 mm to Ø 15.5 mm) through it (see fig. 5-11).
4. Connect the protective conductor (max. 2.5 mm²) to the provided connection (15) (see fig. 5-11).
5. Connect the conductors to the connections (14) of the switching elements (13) as described in the connection diagram inside the cover (12) of the pull-rope emergency stop switch (see figures 5-11 and 5-12).
6. Tighten the nuts of the screwed cable gland (17) with a **tightening torque of 6.7 Nm**.

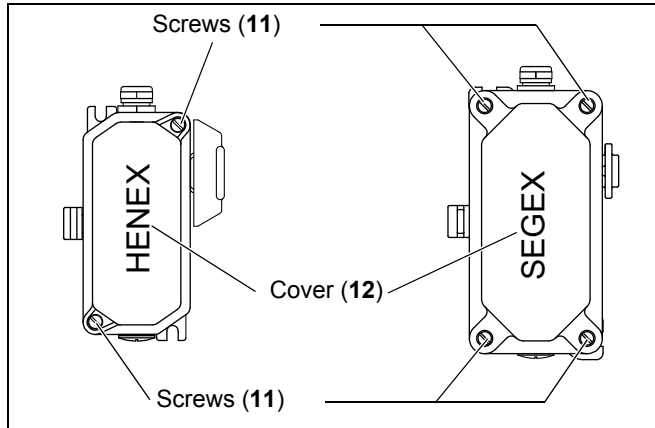

Fig. 5-10: Removing the cover

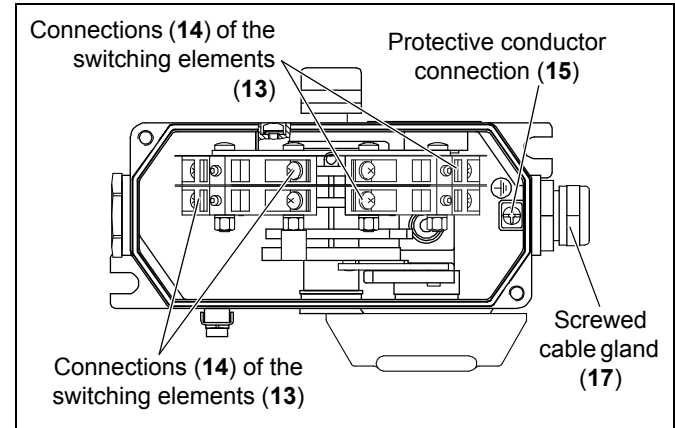

Fig. 5-11: Connecting the switch and protective conductor

**Beware!**

Do not use a device with a damaged gasket. Remove any dust that may have entered the casing (25).

7. Check the gaskets of the cover (12) for damage.
8. Close the cover (12) of the pull-rope emergency stop switch.
9. Secure the cover (12) with the screws (11) (see fig. 5-10).
Tighten the screws (11) **evenly** to a **tightening torque of 1.5 Nm**.

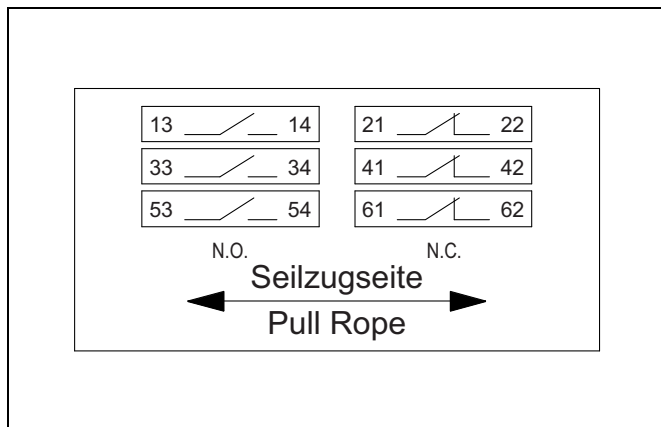

Fig. 5-12: Connect HENEX and SEGEX types

10. Connect each potential equalization conductor with a cross-section of 4 mm² to the potential equalization connections (26) on the cover (12) and the casing (25) (see fig. 5-11).

**Risk of explosion!**

The pull-rope emergency stop switch may be put into operation only if the casing prevents dust and moisture from penetrating the unit.

11. Before putting the pull-rope emergency stop switch into operation, ensure that it is sealed:

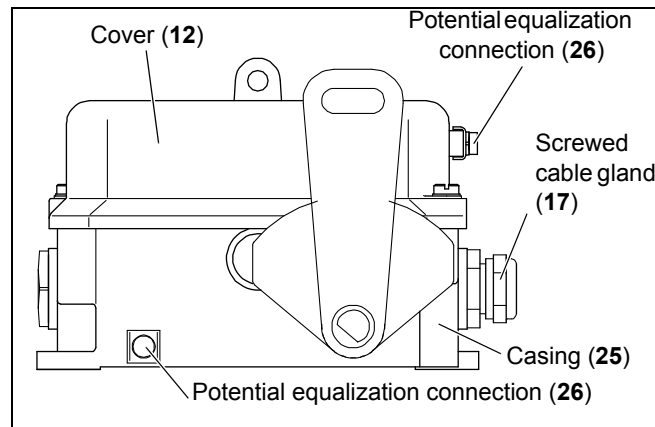

Fig. 5-13: Connecting the potential equalization conductor

- Ensure that the screws (11) on the cover (12) are tightened with a **tightening torque of 1.5 Nm**.
- Check that the screwed cable gland (17) is tightened with a **tightening torque of 6.7 Nm**.
- Check that the dummy plug is fastened tightly.



Risk of explosion!

A damaged pull-rope emergency stop switch or damaged components (e.g. screw connections, gaskets) are not to be used in explosion hazard areas! Damaged pull-rope emergency stop switches must always be replaced.

12. Check the entire pull-rope emergency stop switch and its components for damages.

5.3 Dismounting

Risk of explosion!

Never open the rope-pull emergency stop switch in an explosive, dust-polluted area.

Open the pull-rope emergency stop switch only after it has been de-energized!

Danger of fatal electric shock

Work on the device may be performed only by a qualified electrical technician.

Prior to working, switch off the power supply to the system. Ensure that the system cannot be accidentally switched on. Mask any neighboring components that may be live to prevent contact.

1. Prior to working, switch off the power supply to the system. Ensure that the conveyor system cannot be accidentally switched on. Mask any neighboring components that may be live to prevent contact.
2. Remove the turnbuckles (6) out of the trigger lever (1) (see fig. 6-1).
3. Loosen the potential equalization connections (26) on the cover (12) and the enclosure (25) (see fig. 5-14).

4. Open the cover (12) by loosening the screws (11) (see fig. 5-10).
5. Remove the screwed cable gland (17).
6. Disconnect all electrical connections and pull the cables out of the screwed cable gland (17).
7. Unscrew both screws that fasten the pull-rope emergency stop switch to the conveyor system through the slotted holes and remove the device (see fig. 5-10).

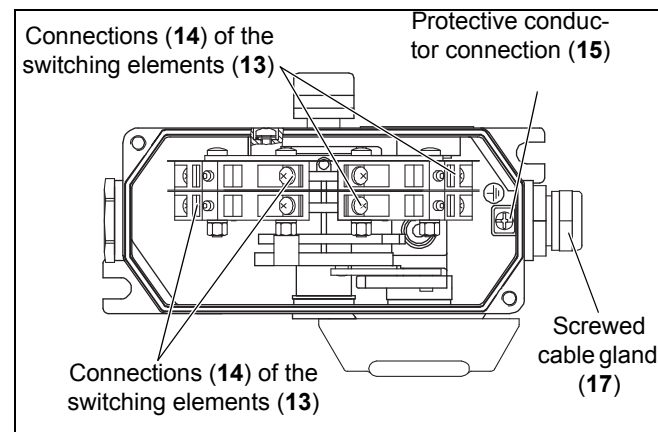

Fig. 5-14: Switch and protective conductor connections

6 Maintenance and repair

Check the pull-rope emergency stop switch and the tear rope system at regular intervals (approximately every three months) to ensure that they are in proper condition and function smoothly.



Risk of explosion!

The pull-rope emergency stop switch may be put into operation only if the casing prevents dust and moisture from penetrating the unit.



Risk of explosion!

Do not use damaged pull-rope emergency stop switches or damaged components (e.g. bolted connections, gaskets) in potentially explosive areas.

Damaged pull-rope emergency stop switches must always be replaced.

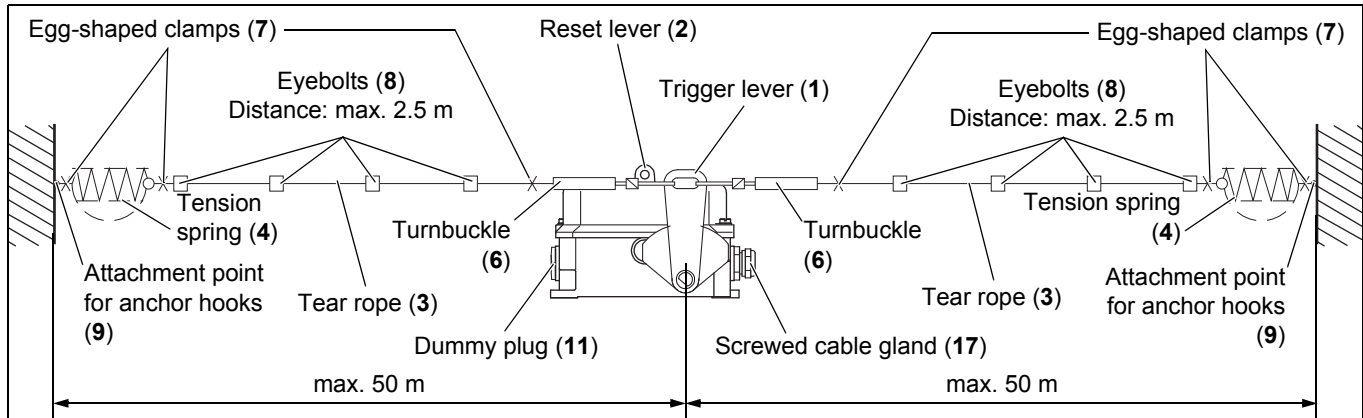

Fig. 6-1: Mounting on the conveyor structure

Defective pull-rope emergency stop switches can be sent to the manufacturer Vossloh Kiepe GmbH for repair (see *Legal Notice for business address*).

7 Ordering devices, replacement parts and accessories

7.1 Ordering devices

Please provide the following data with every order (see legal notice for company address):

1. Pull-rope emergency stop switch type

(see rating plate on casing):

e.g. HENEX 001

2. Product number (see rating plate on casing cover):

e.g. 91.058642.001 (see section 4.2, page 14)



Abb. 7-1: Printed image

7.2 Ordering replacement parts and accessories

Please provide the following data with every order (see *legal notice for company address*):

- Pull-rope emergency stop switch type**
(see *rating plate on casing*):
e.g. HENEX 001
- Product number** (see *rating plate on casing cover*):
e.g. 91.058642.001 (see *section 4.2, page 14*)

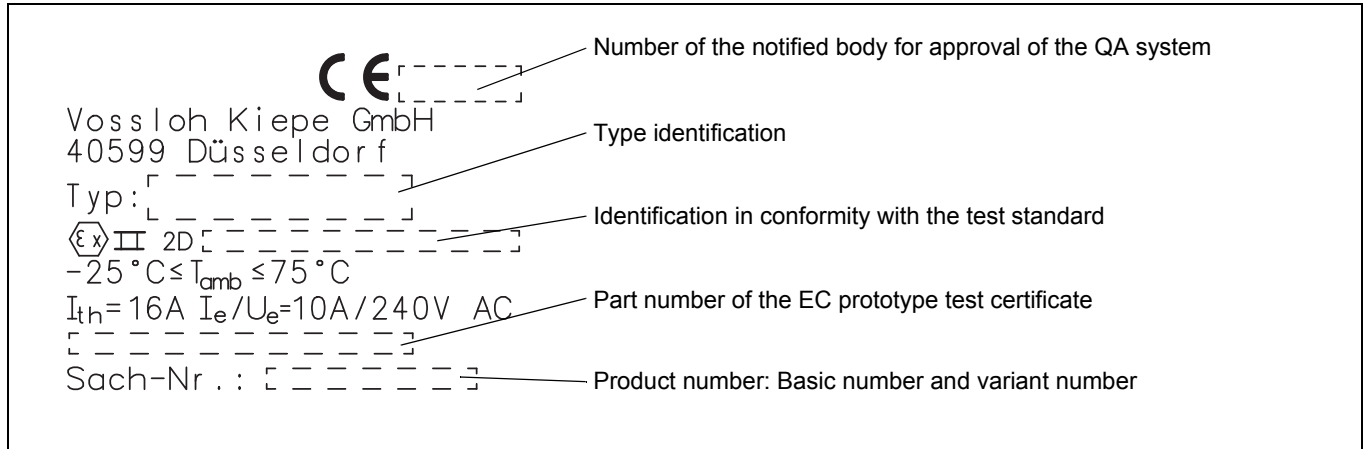
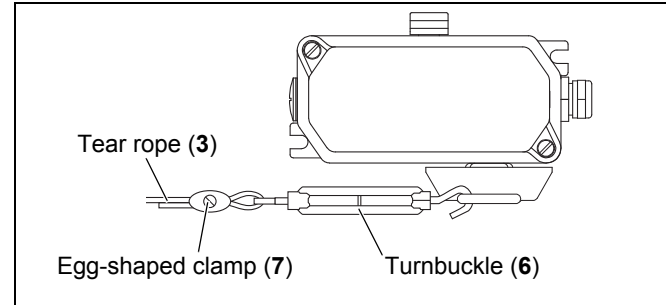

Fig. 7-3: Accessories

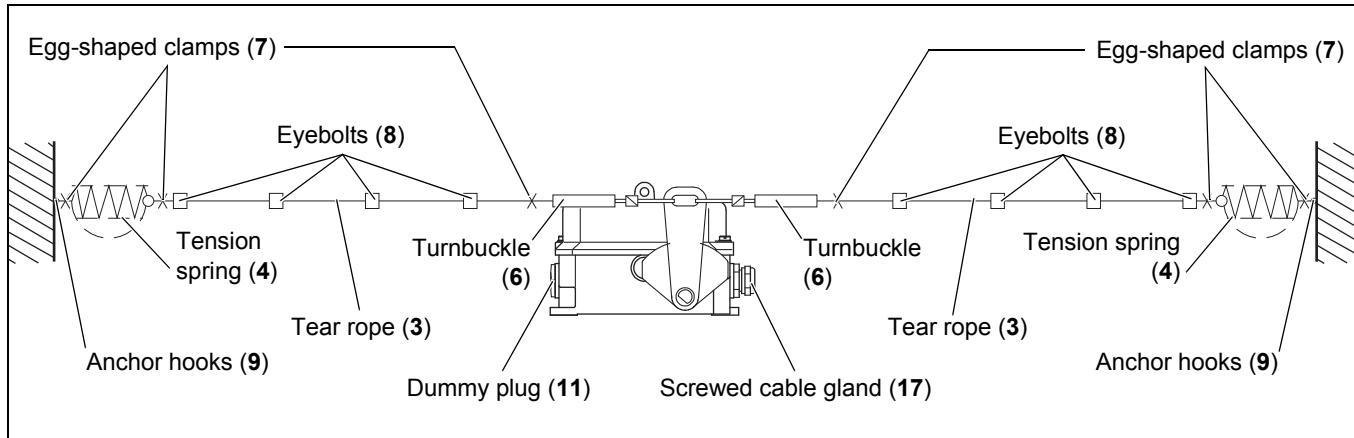

Fig. 7-2: Accessories

3. **Order information and order number** (see table):
e.g. tear rope, 94.045731.001

Item	Order information	Order number
3	Tear rope red, flexible steel wire, plastic coated Ø 3 mm Roll 50 m Roll 100 m Roll 500 m	94.045731.011 94.045731.021 94.045731.031
4	Tension spring made of rust and acid-resistant steel, 170 mm x Ø 20 mm	94.000 026.681
6	Turnbuckle (metal, 1 hook, 1 eye)	215.22.80.02.01
7	Egg-shaped clamp for tear rope of Ø 3 mm	94.047 869.001
8	Eyebolt M 12 x 60 M 12 x 200	94.045 727.001 94.045 727.002
9	Anchor hook M 10	94.045 728.001
11	Ex-dummy plug	113.52.87.20.01
17	Ex-screwed cable gland	113.52.01.20.01



Warning!

The device must only be operated when all three holes are closed with the supplied cable gland (17) and the dummy plugs (11).

Use only screwed cable glands (17) and dummy plugs (11) recommended by the manufacturer and supplied with the device. These screwed cable glands (17) and dummy plugs (11) are designed in compliance with EU design sample test certification. If other screwed cable glands (17) and dummy plugs (11) are used, the device type approval may be rendered void.

www.kiepe-elektrik.com

Vossloh Kiepe GmbH
Kiepe-Platz 1
40599 Düsseldorf
Germany

Tel.: +49 (0) 211 / 74 97 – 0
Fax: +49 (0) 211 / 74 97 – 420
E-mail: info@vkd.kiepe-elektrik.com