

# Pulse Generator Type DG

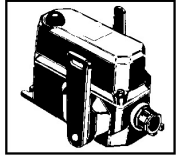

## OPERATING INSTRUCTIONS

## **CE Sign and Conformity**

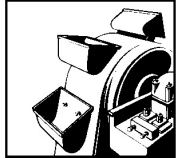
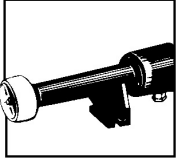
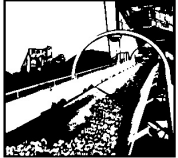
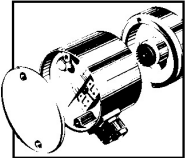



---

The device meets the requirements of the valid European and national regulations.

Conformity has been proved and the corresponding declarations and documents are deposited with the manufacturer.



## Table of Contents

	<b>1</b>	<b>For Your Own Safety</b> .....	<b>5</b>
	1.1	Intended Application.....	5
	1.2	Symbols.....	5
	<b>2</b>	<b>Transport, Packing, Storage and Disposal</b> .....	<b>6</b>
	2.1	Transport and Packing.....	6
	2.2	Storage.....	6
	2.3	Disposal.....	6
	<b>3</b>	<b>Design and Function</b> .....	<b>7</b>
	3.1	2-Wire Pulse Generator according to NAMUR-EN 50227.....	7
	3.2	PNP Switching 3-Wire Pulse Generator.....	7
	<b>4</b>	<b>Technical Data</b> .....	<b>8</b>
	4.1	General Technical Data.....	8
	4.1.1	Standards and Regulations.....	8
	4.1.2	Electrical Data.....	8
	4.1.3	Mechanical Data.....	9
	4.2	Dimensions.....	10

**5 Mounting and Dismounting ..... 11**

5.1 Scope of Supply ..... 11

5.2 Mounting ..... 11

5.2.1 General Mounting Instructions ..... 11

5.2.2 Mounting and Connecting the Pulse Generator ..... 12

**6 Ordering Devices ..... 13**



# 1 For Your Own Safety

## 1.1 Intended Application

The pulse generators of the DG type series generate pulses, the frequencies of which depend on the rotational speed. The pulse generators are particularly suited for application if high accuracy of operation, long service life as well as wear and corrosion resistance are important. The pulse generators meet the high requirements of the relevant regulations. The device is intended for use in stationary installations and in vehicles.

Applications other than specified and unauthorized modifications to the device or its components can lead to injury to persons and damage to the device, for which the manufacturer is **not liable**.

Make sure that the intended use is not impaired in any way, even after unexpected outside influence on the device.

"Intended application" particularly means that any work performed with or on the device is to be carried out in accordance with these **operating instructions**. Only **skilled persons** who are familiar with the **Regulations on the Prevention of Accidents** as well as the other

generally accepted safety rules are allowed to work on this device.

**You protect yourself and prevent damage to the device when you apply the device as intended!**

## 1.2 Symbols

Please pay particular attention to the text passages that are marked with the following symbols:



**Danger!**

**Information that has to be observed at all events in order to protect the user from being injured.**



**Attention!**

**Information that has to be observed in order to prevent damage to the device.**



Helpful additional information



## 2 Transport, Packing, Storage and Disposal

### 2.1 Transport and Packing

Choose a suitable packing when you send the device or components to Vossloh Kiepe GmbH e.g. for repair. Take great care that the device is protected against shocks and humidity. In this way damage to the device due to transport is prevented, for which the manufacturer is not liable.

### 2.2 Storage

Avoid significant variations in temperature as this can lead to condensed water, which might damage the device.

The permissible storage temperature is between  $-25^{\circ}\text{C}$  and  $+70^{\circ}\text{C}$ .



**Attention!**

**Keep the device clean and dry.**

### 2.3 Disposal

Reuse the **packing material**, if possible, or dispose of it in an environment-friendly way.

Send **defective devices and components** to Vossloh Kiepe GmbH for correct recycling or disposal (*see company address on back cover*).



## 3 Design and Function

The pulse generators of the DG type series generate pulses, the frequencies of which depend on the rotational speed. The pulse sequences are analysed by rotational speed monitoring devices. The pulse generators have a proximity-type design and work contactlessly. They are particularly suited for application if high accuracy of operation, long service life as well as wear and corrosion resistance are important.

### 3.1 2-Wire Pulse Generator according to NAMUR-EN 50227

Essentially, these pulse generators consist of a transistor oscillator, the high-frequency stray field of which makes up the response zone. When a metallic object is immersed into the effective area of the stray zone, the resonant circuit is short-circuited, and its internal resistance becomes high-impedance. The oscillations stop and the current consumption of the pulse generator decreases. This current change is analysed by the rotational speed monitoring devices.

### 3.2 PNP Switching 3-Wire Pulse Generator

These pulse generators differ from the NAMUR pulse generators by an additional downstream flip-flop, which effects a change of the output potential from GND to  $+U_B$  when the active zone is damped. These pulse generators can also be directly connected with a PLC.

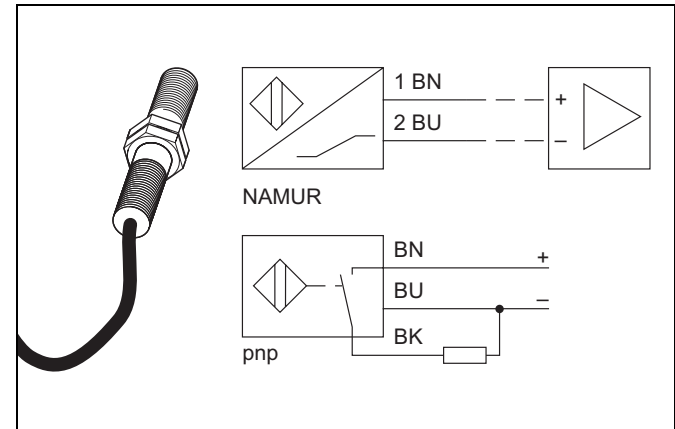

Fig. 3-1: Pulse generator of the DG type series



## 4 Technical Data

### 4.1 General Technical Data

#### 4.1.1 Standards and Regulations

EN 60947-5-2	Low-voltage Switchgear and Controlgear - Part 5: Control Circuit Devices and Switching Elements - Section 2: Proximity Switches
EN 50 227 (NAMUR)	Control Circuit Devices and Switching Elements, Proximity Sensors, DC Interface for Proximity Sensors and Switching Amplifiers (NAMUR)
EN 50081 – 2	Electromagnetic Compatibility (EMC) - Generic Emission Standard - 2: Industrial Environment
EN 50082 – 2	Electromagnetic Compatibility (EMC) - Generic Immunity Standard - 2: Industrial Environment
VDE 0110 (pollution degree 3)	Insulation Co-ordination for Equipment within Low-voltage Systems

#### 4.1.2 Electrical Data

2-wire pulse generator acc. to NAMUR-EN 50227	DG 5 ...	DG 10 ...
Rated operational voltage $U_B$	DC 8.2 V	DC 8.2 V
Internal resistance $R_i$	1,000 $\Omega$	1,000 $\Omega$
Output current $I_{\text{actuated}}$	$\leq 1.2$ mA	$\leq 1.2$ mA
Output current $I_{\text{not actuated}}$	$\geq 2.1$ mA	$\geq 2.1$ mA
Operating frequency	1 kHz	0.5 kHz
Rated operating distance $s_n$ (total tolerance zone: $0.81 s_n \dots 1.21 s_n$ ; dependent on the material of the actuating object)	5 mm	10 mm

2-wire pulse generator acc. to NAMUR-EN 50227	DG 5 ...	DG 10 ...
Fitting	flush	flush
Connecting lead	2 x 0.5 mm <sup>2</sup> , 2 m long	2 x 0.5 mm <sup>2</sup> , 2 m long
PNP switching 3-wire pulse generator	DGP 5	DGP 10
Rated operational voltage $U_B$	DC 10 ... 30 V, completely polarized	DC 10 ... 30 V, completely polarized
Rated operational current $I_e$	200 mA	200 mA
Idle current $I_0$	≤ 10 mA	≤ 10 mA
Operating frequency	1 kHz	0.5 kHz
Rated operating distance $s_n$ (total tolerance zone: 0.81 $s_n$ ... 1.21 $s_n$ ; dependent on the material of the actuating object)	8 mm	10 mm
Fitting	flush	flush
Connecting lead	3 x 0.34 mm <sup>2</sup> , 2 m long	3 x 0.34 mm <sup>2</sup> , 2 m long

### 4.1.3 Mechanical Data

Type	Threaded pipe	Housing diameter	Tightening torque	Width across flats	Nut thickness
DG 5, DGP 5*	M 18 x 1	18 mm	25 Nm	SW 24	4 mm
DG 10, DGP 10*	M 30 x 1.5	30 mm	90 Nm	SW 36	5 mm
DG 5 TH/TN/S**	M 18 x 1	18 mm	2 Nm	SW 24	8 mm
DG 10 TH/TN/S**	M 30 x 1.5	30 mm	5 Nm	SW 36	10 mm

\* Housing: chromium-plated brass; active surface: PA 12-GF30

\*\* Housing: PA 12-GF30; active surface: PA 12-GF30

Degree of protection (acc. to EN 60529) IP 67

Temperature range

Standard	-25 °C ... +70 °C
DG 5 TN, DG 10 TN*	-40 °C ... +70 °C
DG 5 TH, DG 10 TH*	-25 °C ... +100 °C

\* The TH and TN designs are also resistant to oil, petrol and alkaline solutions.

## 4.2 Dimensions

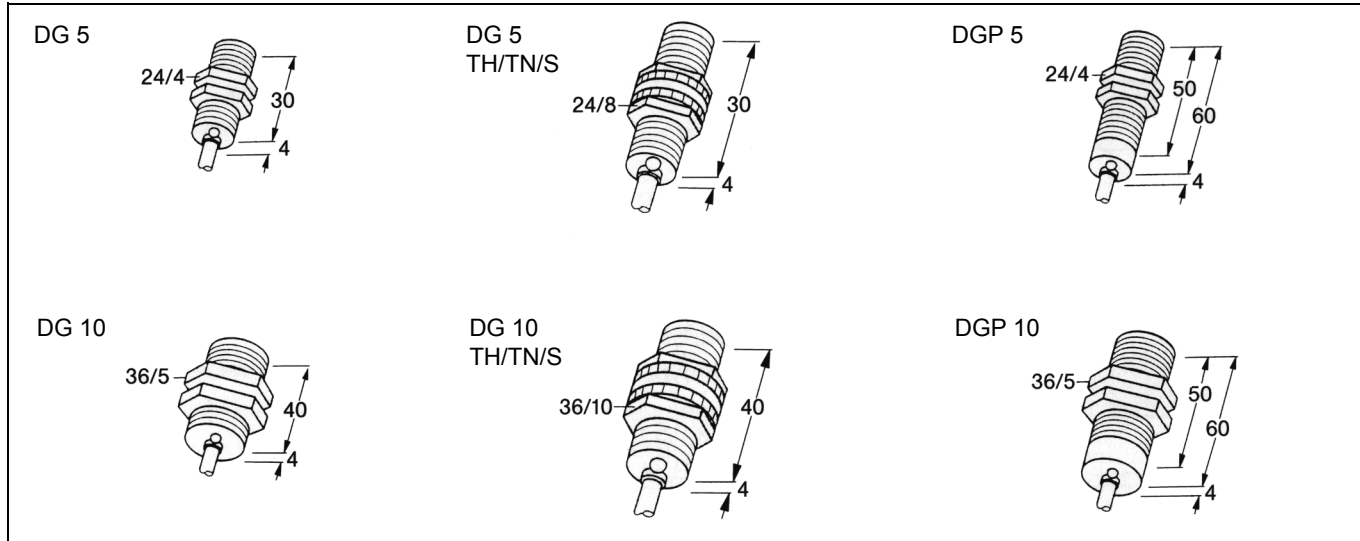

Fig. 4-1: Mounting dimensions



## 5 Mounting and Dismounting

### 5.1 Scope of Supply

The pulse generators are delivered ready for operation. The fixing nuts (1) or the plastic clip (2) together with the weld-on plate (3) are included in the scope of supply (see fig. 5-2).

### 5.2 Mounting



**Danger to life – electric shocks!**

**The mounting and the electrical connection may only be carried out by skilled electricians.**

**De-energize the plant before the mounting. Prevent unintentional reclosing of the plant. Cover the adjacent, live parts in a shockproof way.**

#### 5.2.1 General Mounting Instructions

The pulse generators are to be so installed that one or several metal parts (Fe metals, if possible) can rotate past the head (4) of the pulse generator within the response distance (see fig. 5-1). One pulse is generated per metal part. Pulse multiplication via symmetrical arrangement of several metal parts is recommended for low rotational speeds. The metal parts should at least have the dimension of the head (4) of the pulse generator, and the distance between any two parts should not be below the double diameter of the pulse generator.

The pulse generator is fastened with two fixing nuts (1) or by means of the enclosed plastic clip (2) and the weld-on plate (3) (see figs. 5-1 and 5-2). The pulse generators are also suited for a flush fitting. They can be screwed directly into a thread.

In order not to influence the responsiveness of the pulse generator, the distance between the head (4) of the pulse generator and the metallic machine parts has to be at least 24 mm for M 18 pulse generators and 30 mm for M 30 pulse generators.

### 5.2.2 Mounting and Connecting the Pulse Generator

1. De-energize the plant before the mounting and prevent unintentional reclosing of the plant.
2. Mount the pulse generator with due regard to the mounting instructions in section 5.2.1 and the mechanical data in section 4.1.3.
3. Connect the pulse generator in accordance with the wiring diagram (see fig. 5-1).

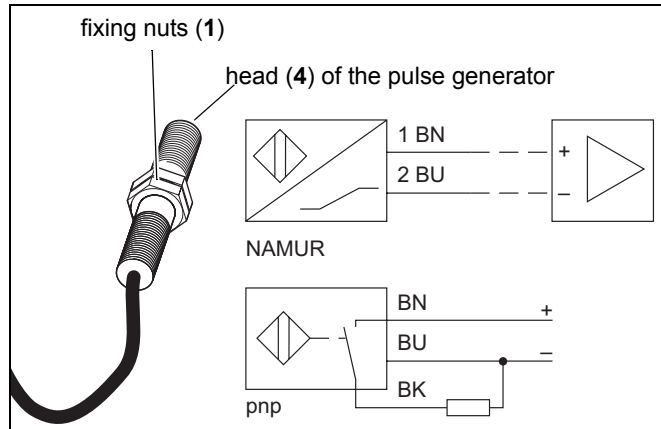

Fig. 5-1: Pulse generator of the DG type series

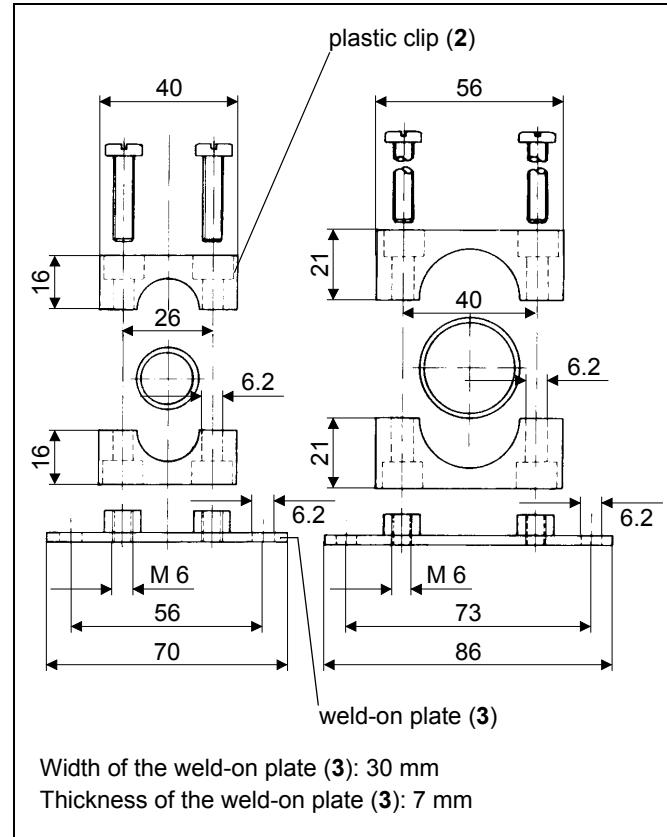

Fig. 5-2: Mounting the pulse generator



## 6 Ordering Devices

Please always quote the pulse generator type and the device identification number when you place a purchase order with Vossloh Kiepe GmbH (*see company address on back cover*):

Type	Device identification No.
DG 5	96.040 610.105
DG 5 TH	215.36.01.02.11
DG 5 TN	215.36.01.02.10
DGP 5	383.06.07.20.00
DG 10	96.040 610.110
DG 10 TH	215.36.01.02.16
DG 10 TN	215.36.01.02.15
DGP 10	383.06.07.03.00
DG 10 S	383.06.07.02.00





Vossloh Kiepe GmbH ● Kiepe-Platz 1 ● D-40599 Düsseldorf  
Tel.: +49 (0) 211 74 97 – 0 ● Fax: +49 (0) 211 74 97 – 300  
Internet: <http://www.vossloh-kiepe.com> ● E-Mail: [info@vkd.vossloh.com](mailto:info@vkd.vossloh.com)

---

Copyright reserved – Subject to changes

Doc. Ident. No.: 94.056 264.191

Edition: 11.10.2006

Modification Index: D