

Electronic Speed Monitor

EDO

Leaflet No. Kiepe 101



APPLICATION

The electronic speed monitor relay EDO is used in connection with a pulse sensor to monitor the rotational speed and standstill of drives.

Pulse sensors according to NAMUR EN 50227 as well as 3-wire-sensors can be connected to the EDO relay. The pulse output is fed to the speed monitor relay where the pulse frequency is compared with the frequency set by the control of the relay. When the input frequency passes the set frequency the internal output relay is switched.

Warning or control equipment can be connected to this output relay and operate when the speed either increases or decreases from the setpoint.

The new multi-layer contact of the output relay improves the true operation of the contact in a wide range up to 5 A and 250 V. The operation of the relay can be inhibited during start-up of the monitored drive by adjusting the start-up potentiometer to the time taken for the drive to reach operating speed.

Options

- A special design is available to meet requirements where the speed monitor unit should be installed close to the monitored drive and its pulse sensor.

The design consists of speed monitor relay EDO being installed in a plastic housing, of IP65 protection. The true operation of the device can be readily observed through the transparent cover of the plastic housing.

The features of this arrangement are:

- Shortened length of screened cable between pulse sensor and relay adjustment at commissioning with visual contact to the drive.
- The output signal of the relay can be interference free transmitted to the control equipment without using the screened cable.
- A feature of the Kiepe speed monitor relays is that any number of speed monitors can be connected to only one transducer. The pre-set trip points of the individual speed monitor relays can be varied.

OPERATING PRINCIPLE

The circuit arrangements of the speed monitor relay EDO makes use of the advantages of digital pulse input. There are no time lags normally encountered with analog devices. The unit compares the time between successive input pulses and its pre-set frequency.

Differences result in immediate switch-off of the output relay. The output relay will switch, too, if the connected pulse sensor becomes damaged or the powersupply fails.



SETTING CONTROLS

Start-up delay potentiometer

Operation of the relay can be inhibited during start-up by adjusting the potentiometer over the range of 0 to ≥ 40 sec. depending on the time taken for the monitored drive to reach operating speed.

Pulse range selector switch

The trip point can be adjusted within the range of 6 to 6000 pulses per minute. This total range is divided into 3 continuously adjustable setting ranges.

Pulses / min.	Position of the pulse range switch	Cut-out delay in sec. *
6 ... 60	 1 pulse/min	10 ... 1
60 ... 600	 10 pulse/min	1 ... 0,1
600 ... 6000	 100 pulse/min	0,1 ... 0,01

The maximum operating frequency is 12.000 pulses/min.

The indication beside the pulse range selector switch signifies pulses/min. and not r.p.m..

Pushbutton

Pressing of the pushbutton links the output relay during the adjustment of the trip point and prevents the drive from becoming cut-off during the adjustment.

Setpoint potentiometer

provides trip point adjustment within the range of the adjusted pulse range.

LED-diode, green

indicates state of output relay.

- LED „lit“ means operating speed above setpoint - output relay energized
- LED „off“ means fault, operating speed below trip point - output relay de-energized

LED-diode, orange

This LED will be lit or flashes according to the received pulses. From 1500 pulses/min. up the flashing will change to a continuous light. If the speed monitor relays is under operation, but the orange LED remains to be off (out), either the pulse transducer or the wiring between sensor and relay unit fails.

Additional switch-off delay

In order to avoid spurious fault indications, given by jolt in drive systems the output relay can have a fall off feature by bridging terminals Y 21 - Y 22. Three „switch off delay times“ can be programmed by positioning a jumper located on the lower PCB.

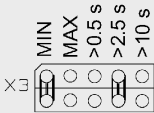
Jumperposition	Switch-off delay in seconds
	> 10,0 s
	> 2,5 s
	> 0,5 s

TECHNICAL DATA

Device complies with	EN 50178-94 EN 50081-1 EN 50082-2
Operating principles	Underspeed, slip, standstill or overspeed monitoring
Mechanical	Relay casing with front terminals. Two PCB's direct soldered to the front terminals
Actuating supply voltage	AC 230 V, 50 ... 60 cyc., (Other voltages by request).
Voltage tolerance	± 10 %
Power consumption	Approx. 3 VA
Ambient temperature	-20 °C ... +55 °C
Storage temperature	-30 °C ... +70 °C
Trip point accuracy	< 1 % (at constant ambient temperature)
Reset differential	10 % at pre-set speed. Can be altered by means of an internal potentiometer to between 3 ... 30 %.
Pulse duration	≥ 2 ms
Start-up delay	0 - 40 sec. adjustability
Protection	Case IP 30, terminals IP 20 according to EN 60529
Mounting contact	Vertical (please refer to dimensions)
Output contact	1 single pole changeover contact

TIME CHARACTERISTIC DIAGRAM

Speed monitor relay Model EDO (underspeed monitoring)

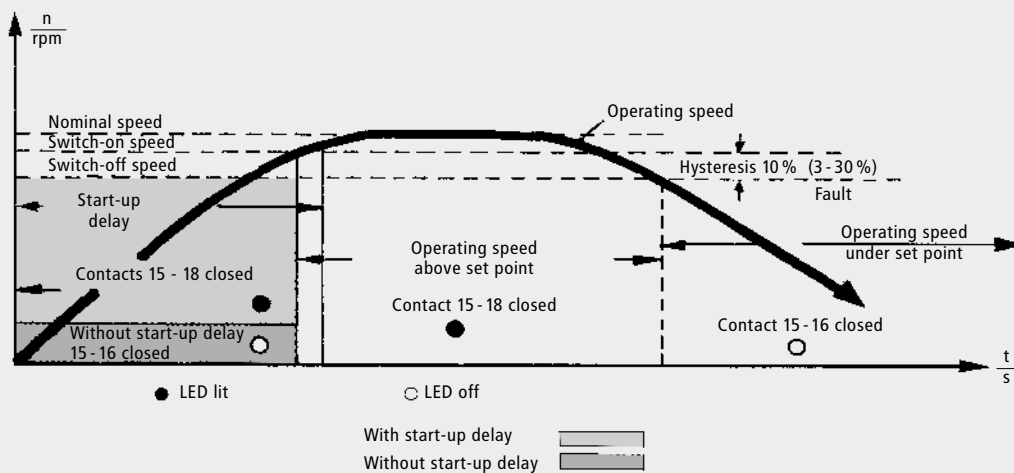

OPERATIONS

EDO used as underspeed or standstill monitor with start-up delay

The internal output relay will be energized and the green LED will be lit until the start-up delay is completed (contact 15 - 18 closed). The relay will be cut off if the operating speed is below the set point and the start-up delay is completed (contact 15 - 16 closed).

EDO used as overspeed (maximum speed) monitor without start-up delay

Move the internal slide switch from position 1 to 2. In this operating mode the unit reacts when the pre-set speed is exceeded, without locking on. The output relay de-energizes, and the green LED goes out. Failure of pulses are not signalled. If this is required, then model EDO should be used.

CONNECTION SAMPLES

Low speed monitoring device with run-up delay

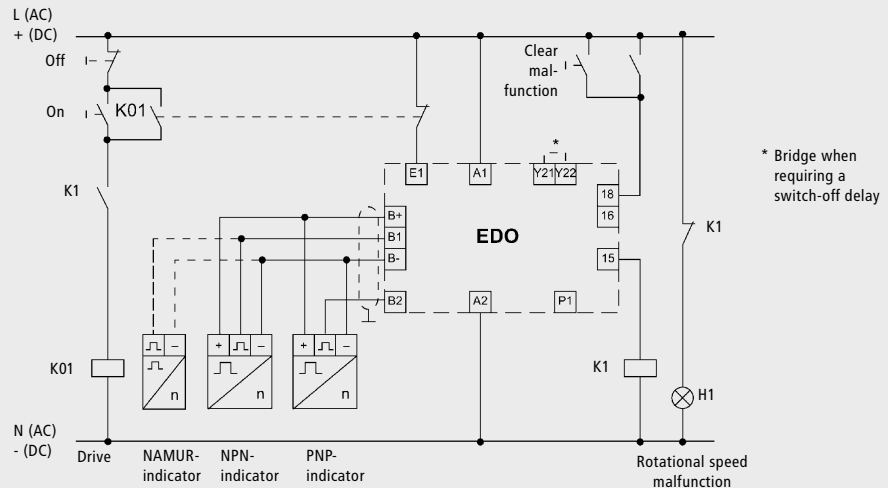

Several speed monitoring devices connected to one pulse indicator

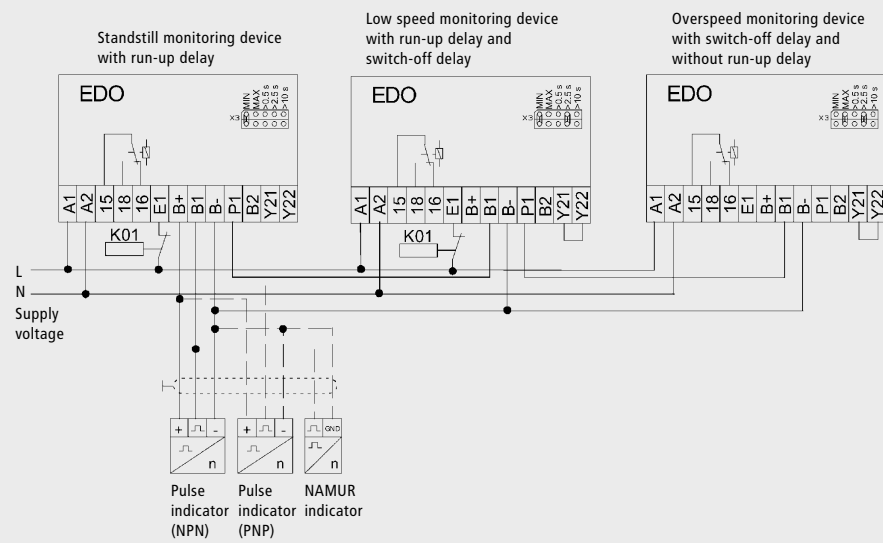

DIMENSIONS

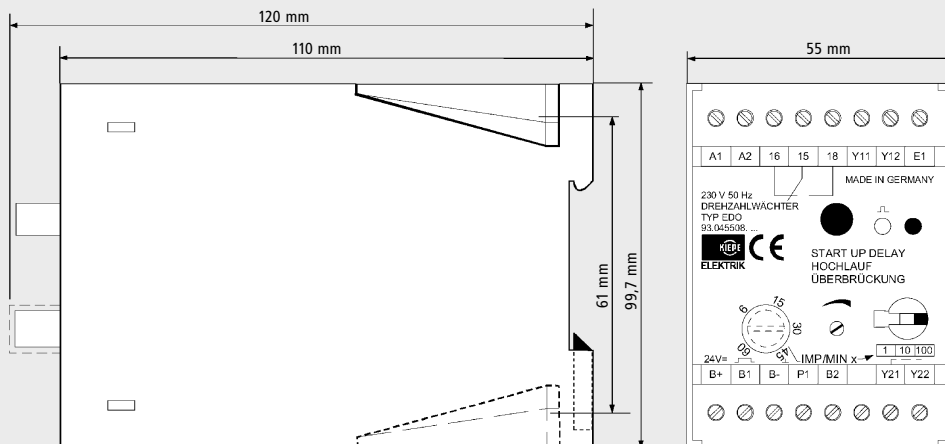

Subject to change without notice.